

DDR_STRBEN is trace to DDR memory
for delay compensation

This net is equal to the DDR_CLKP (or DDR_CLKN)
plus
the length of DDR_DQXX Average Trace length

SPECTRUM DIGITAL INCORPORATED			
Title: DM365 Evaluation Module			
Page Contents: DM365 DDR INTERFACE			
Size: B	DWG NO	510842-0001	Revision: C
Date:	Monday, April 13, 2009	Sheet 2 of	53

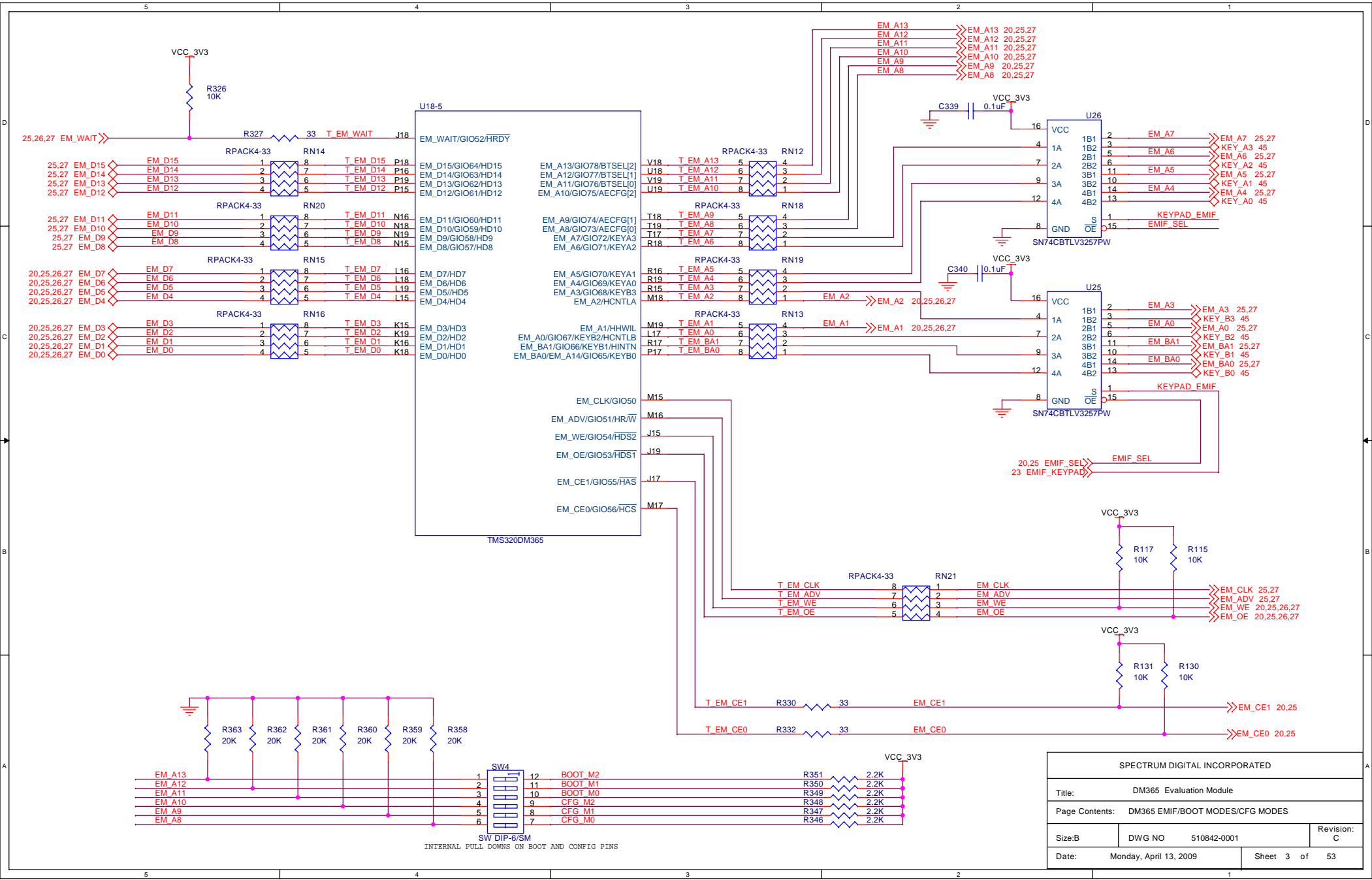

SPECTRUM DIGITAL INCORPORATED			
Title: DM365 Evaluation Module			
Page Contents: DM365 EMIF/BOOT MODES/CFG MODES			
Size: B	DWG NO	510842-0001	Revision: C
Date:	Monday, April 13, 2009	Sheet 3 of	53

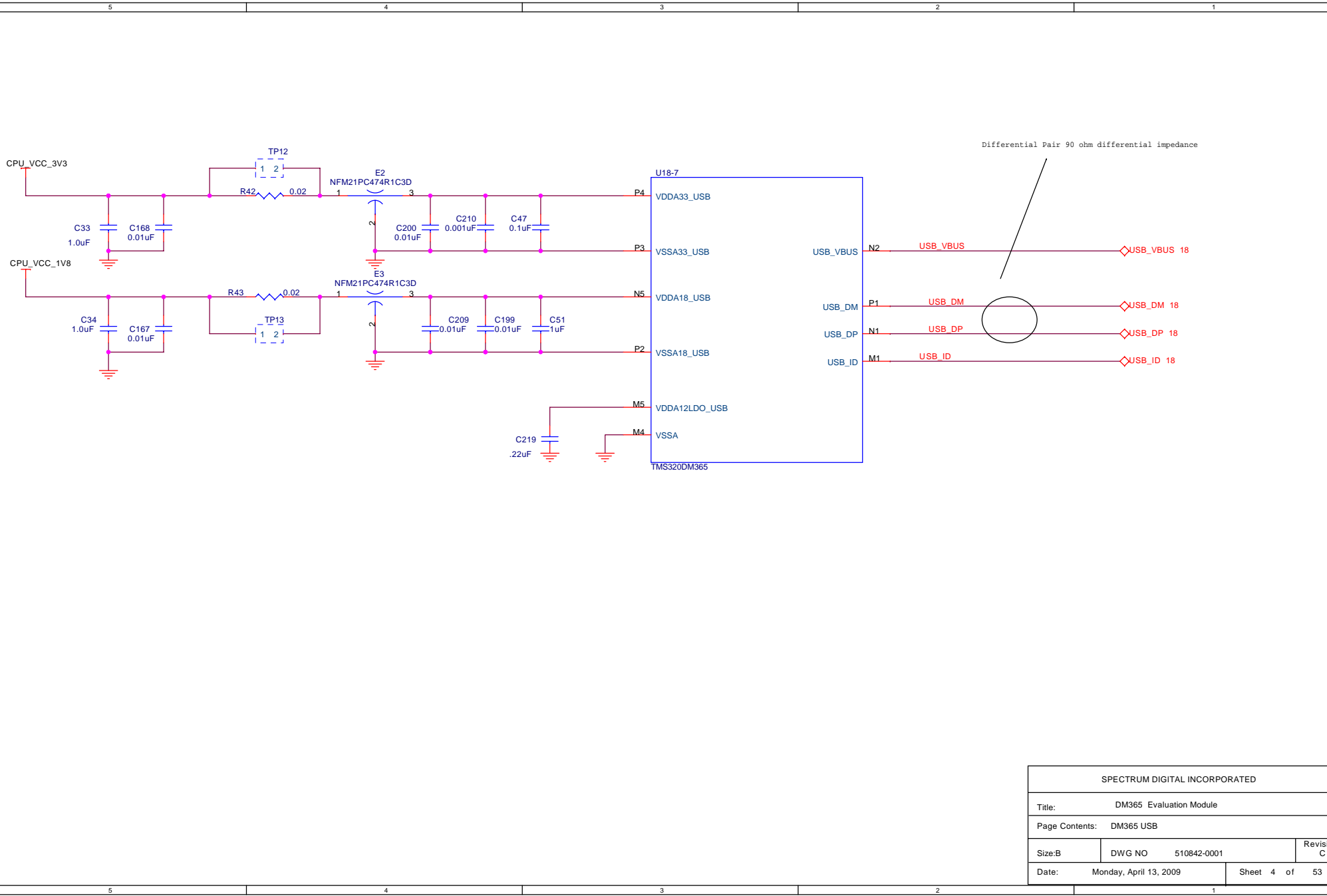

Differential Pair 90 ohm differential impedance

SPECTRUM DIGITAL INCORPORATED			
Title: DM365 Evaluation Module			
Page Contents: DM365 USB			
Size: B	DWG NO	510842-0001	Revision: C
Date:	Monday, April 13, 2009		Sheet 4 of 53

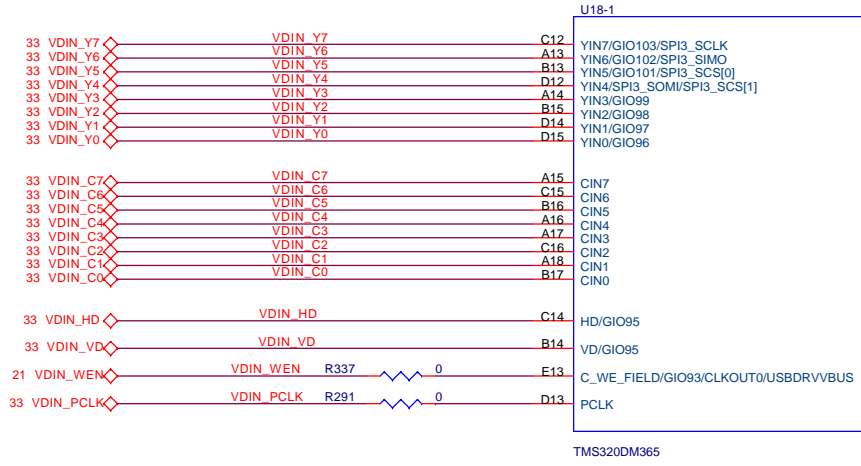

SPECTRUM DIGITAL INCORPORATED			
Title: DM365 Evaluation Module			
Page Contents: DM365 VIDEO IN			
Size: B	DWG NO	510842-0001	Revision: C
Date:	Monday, April 13, 2009	Sheet 5 of	53

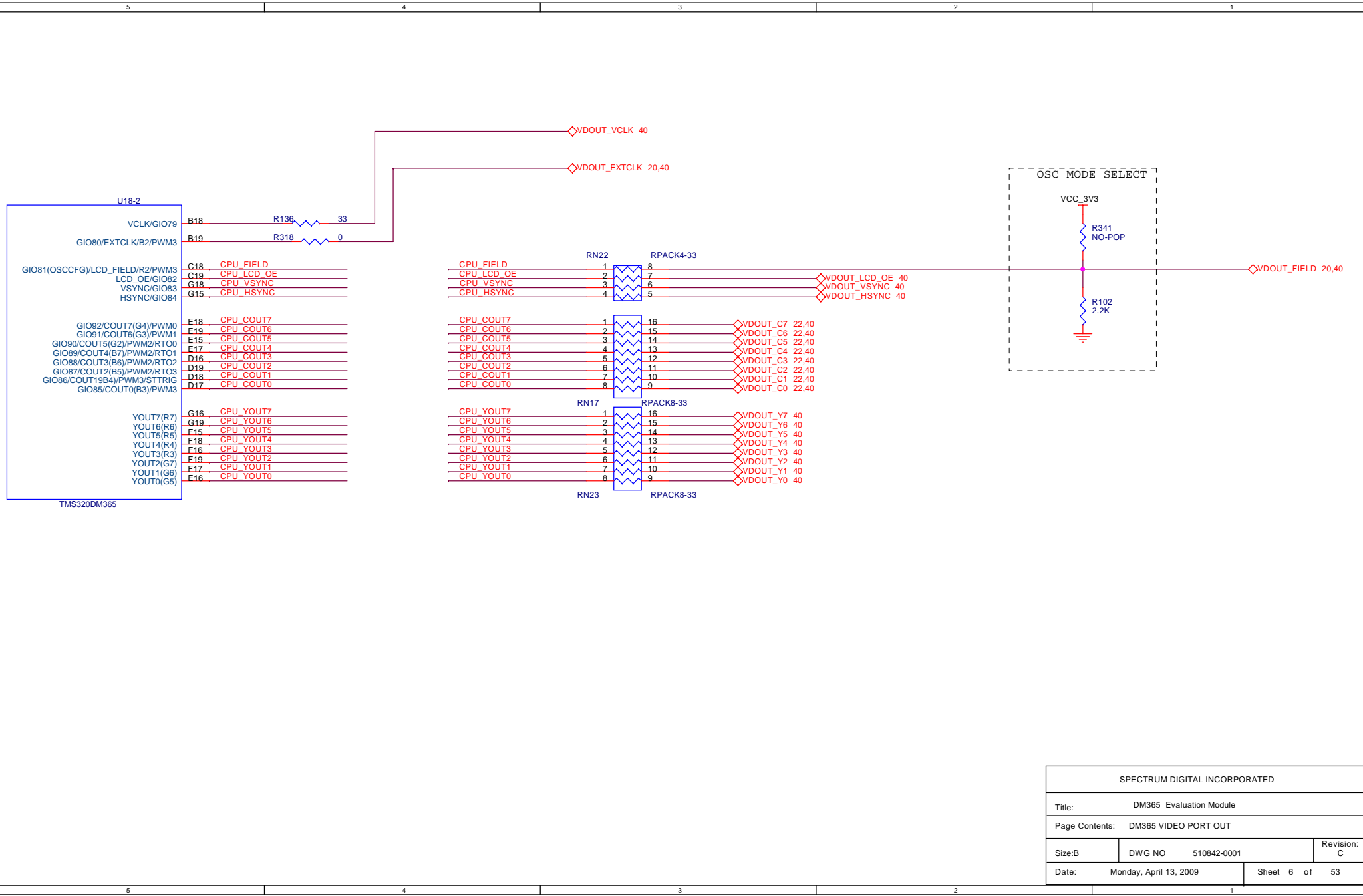

SPECTRUM DIGITAL INCORPORATED			
Title: DM365 Evaluation Module			
Page Contents: DM365 VIDEO PORT OUT			
Size: B	DWG NO: 510842-0001	Revision: C	
Date: Monday, April 13, 2009	Sheet 6 of 53		

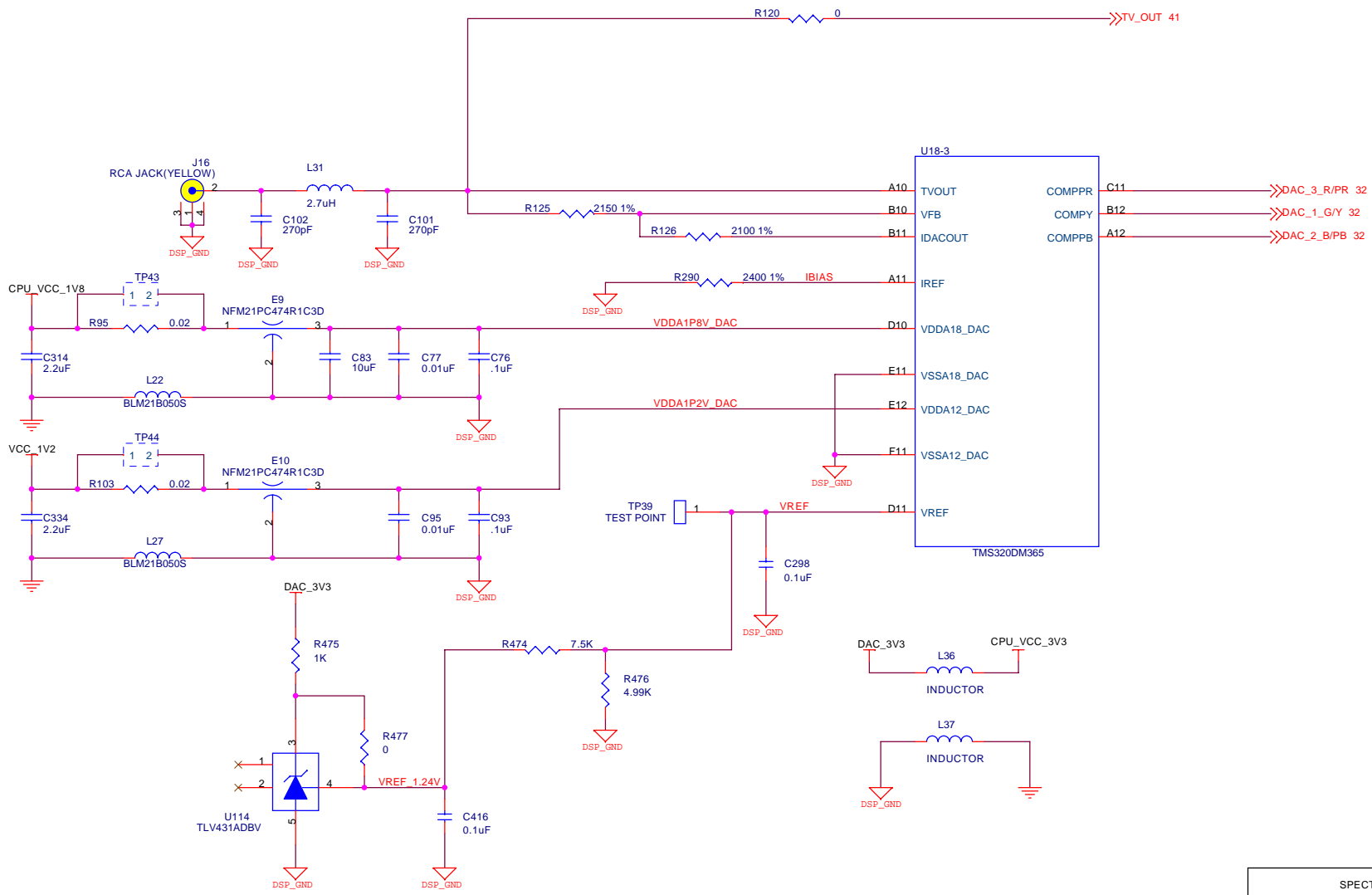

SPECTRUM DIGITAL INCORPORATED			
Title: DM365 Evaluation Module			
Page Contents: DM365 ANALOG VIDEO OUT			
Size: B	DWG NO	510842-0001	Revision: C
Date:	Monday, April 13, 2009	Sheet 7 of	53

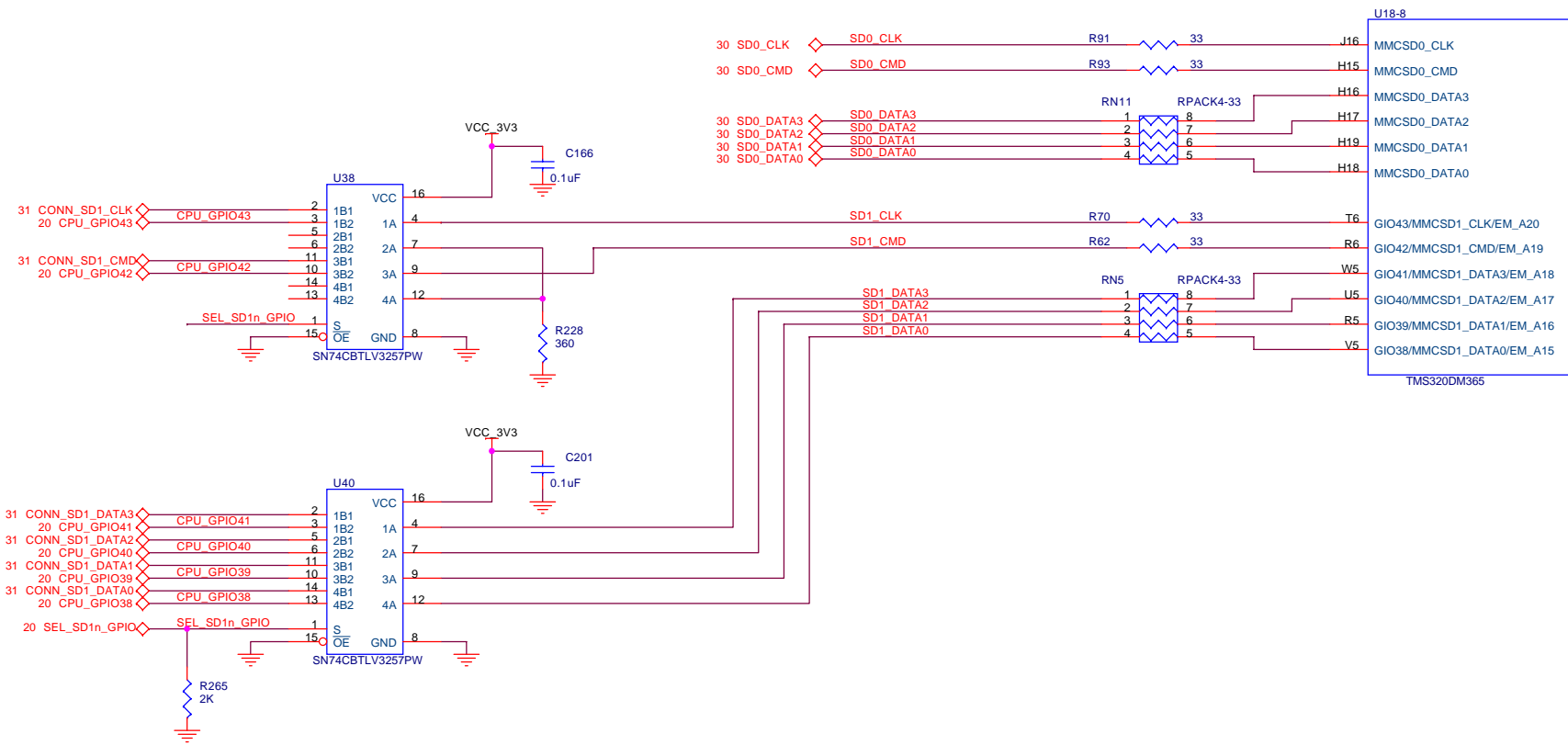

SPECTRUM DIGITAL INCORPORATED			
Title: DM365 Evaluation Module			
Page Contents: DM365 SD/MMC/MS INTERFACE			
Size: B	DWG NO	510842-0001	Revision: C
Date:	Monday, April 13, 2009	Sheet 8 of	53

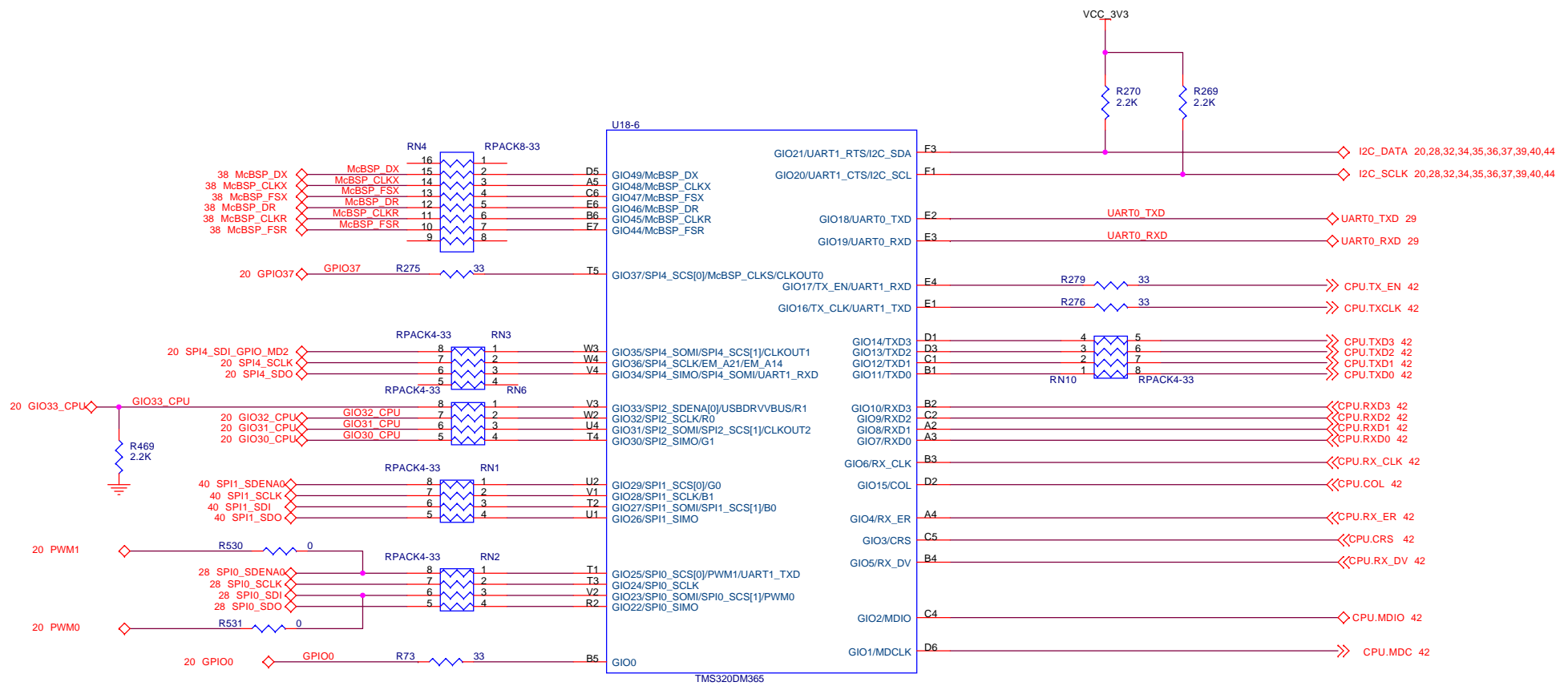

SPECTRUM DIGITAL INCORPORATED			
Title: DM365 Evaluation Module			
Page Contents: DM365 I/O			
Size: B	DWG NO	510842-0001	Revision: C
Date:	Monday, April 13, 2009	Sheet 9 of	53

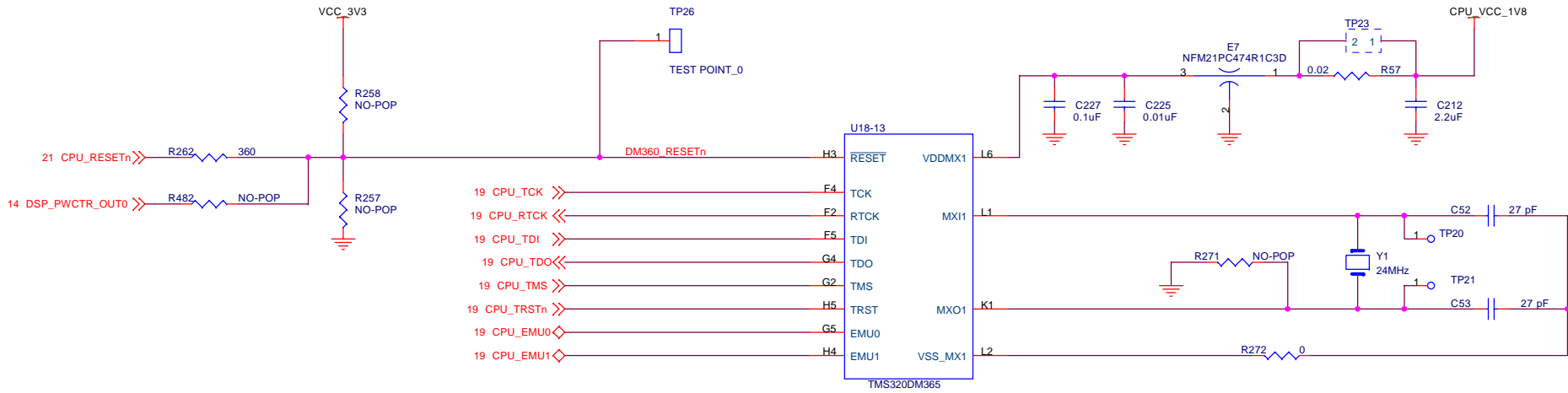

SPECTRUM DIGITAL INCORPORATED			
Title: DM365 Evaluation Module			
Page Contents: DM365 JTAG,RESET,CLOCKS			
Size: B	DWG NO	510842-0001	Revision: C
Date:	Monday, April 13, 2009		Sheet 10 of 53

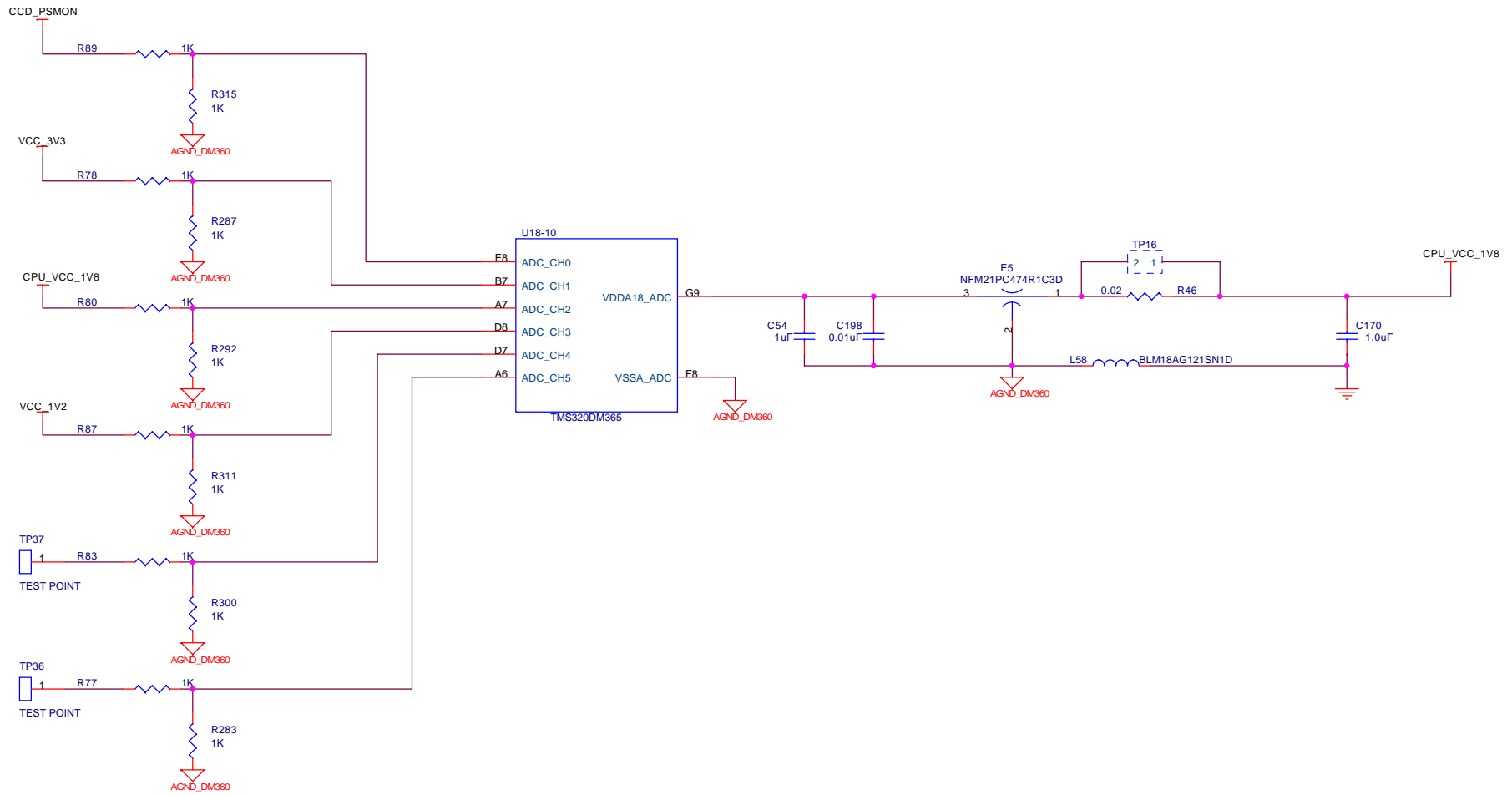

SPECTRUM DIGITAL INCORPORATED			
Title: DM365 Evaluation Module			
Page Contents: DM365 ADC			
Size: B	DWG NO	510842-0001	Revision: A
Date:	Monday, April 13, 2009		Sheet 11 of 53

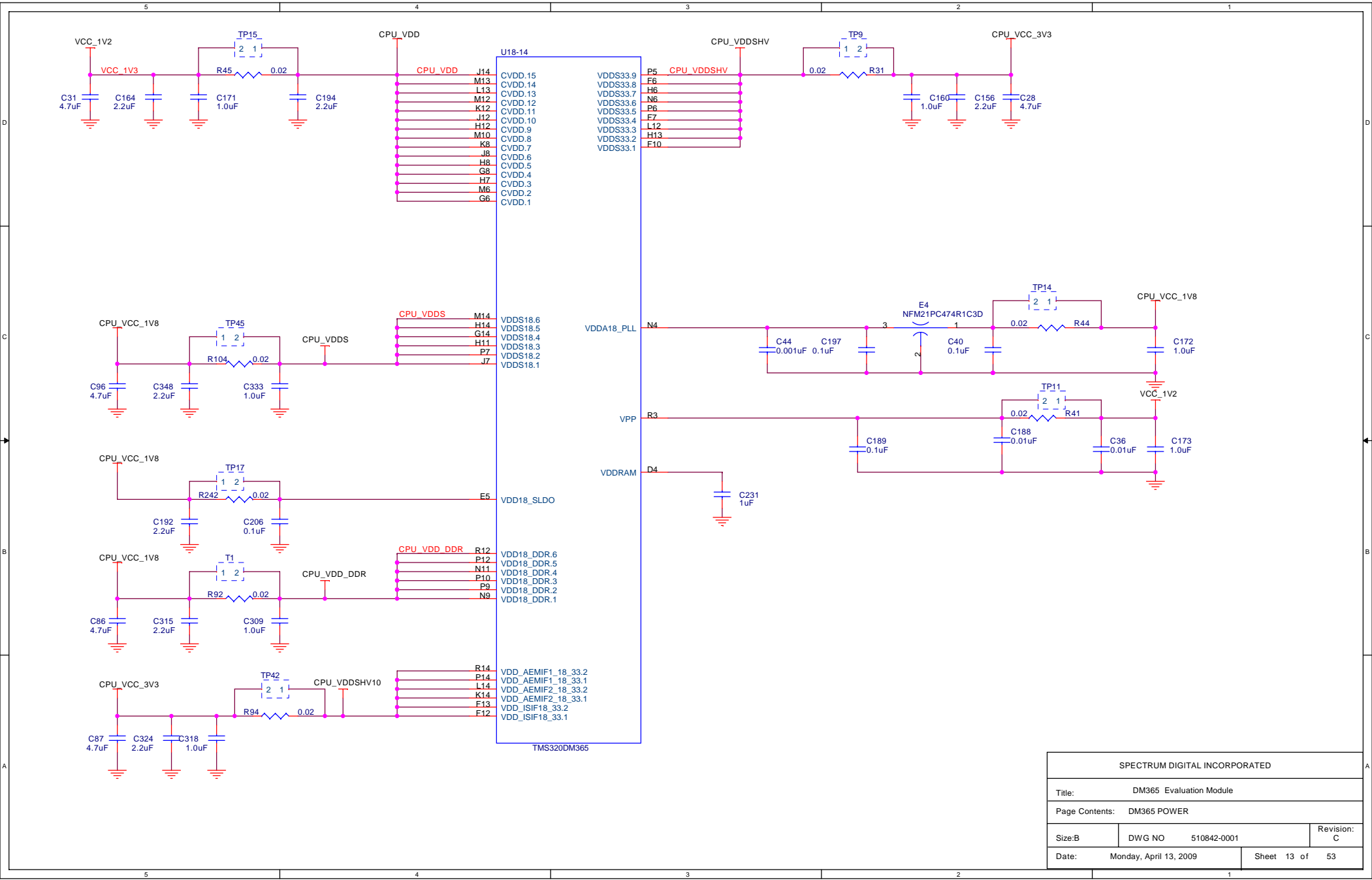

SPECTRUM DIGITAL INCORPORATED			
Title: DM365 Evaluation Module			
Page Contents: DM365 POWER			
Size: B	DWG NO	510842-0001	Revision: C
Date:	Monday, April 13, 2009	Sheet 13 of	53

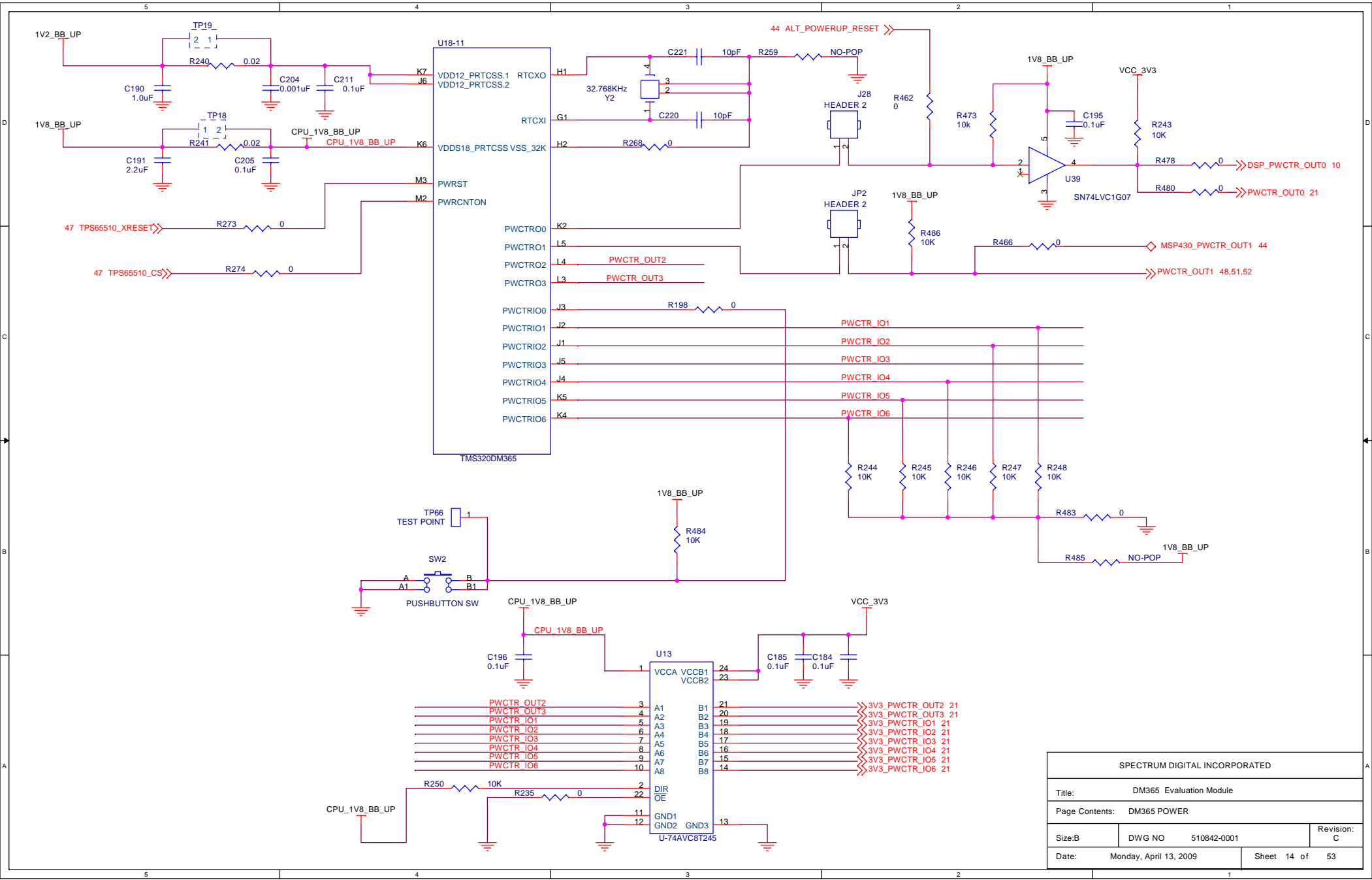

SPECTRUM DIGITAL INCORPORATED			
Title: DM365 Evaluation Module			
Page Contents: DM365 POWER			
Size: B	DWG NO	510842-0001	Revision: C
Date:	Monday, April 13, 2009	Sheet 14 of	53

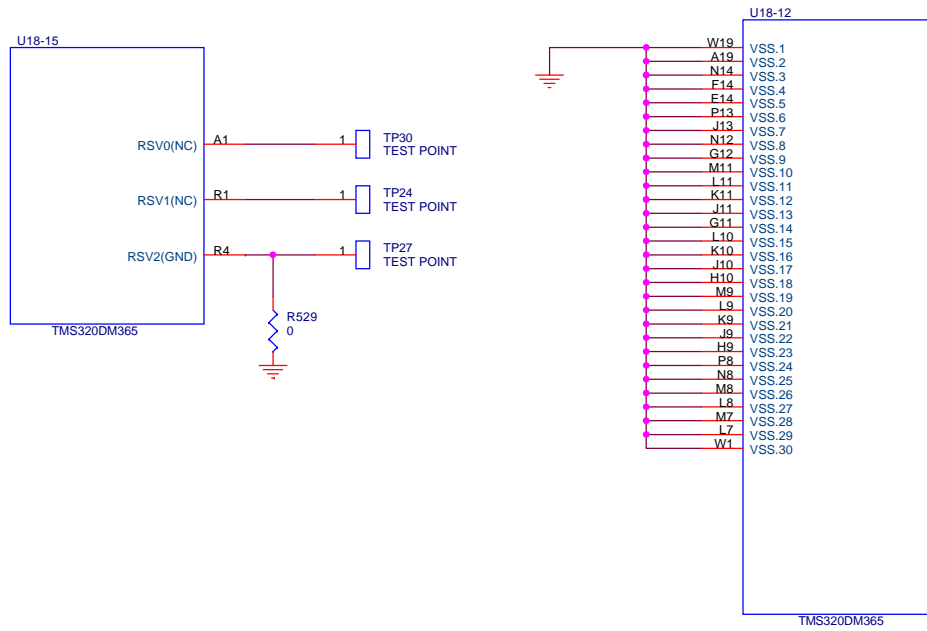

SPECTRUM DIGITAL INCORPORATED			
Title: DM365 Evaluation Module			
Page Contents: DM365 POWER			
Size: B	DWG NO	510842-0001	Revision: C
Date:	Monday, April 13, 2009	Sheet 15 of	53

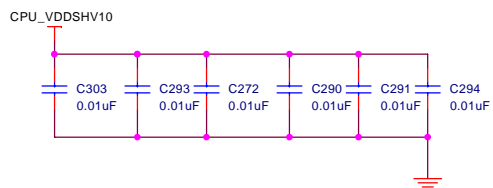
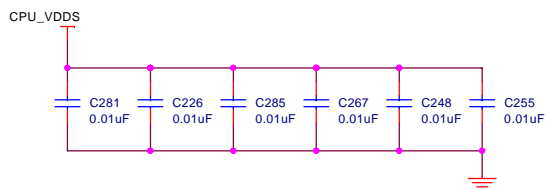
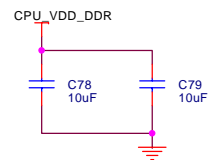
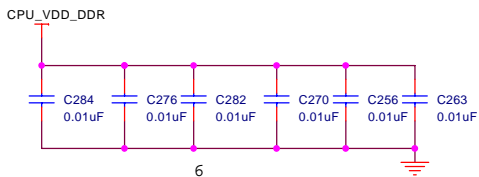
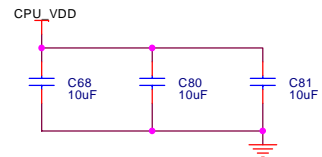
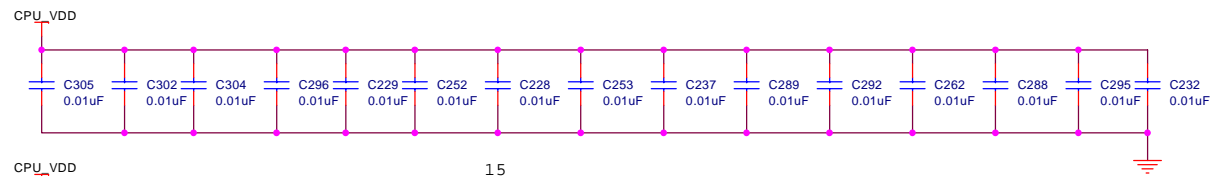

SPECTRUM DIGITAL INCORPORATED			
Title: DM365 Evaluation Module			
Page Contents: DM365 DECOUPLING CAPACITORS			
Size: B	DWG NO	510842-0001	Revision: C
Date: Monday, April 13, 2009		Sheet 16 of 53	

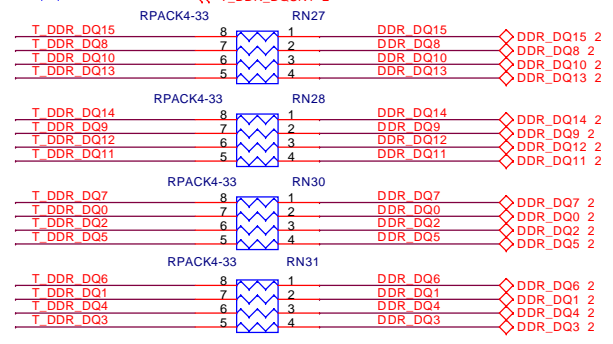
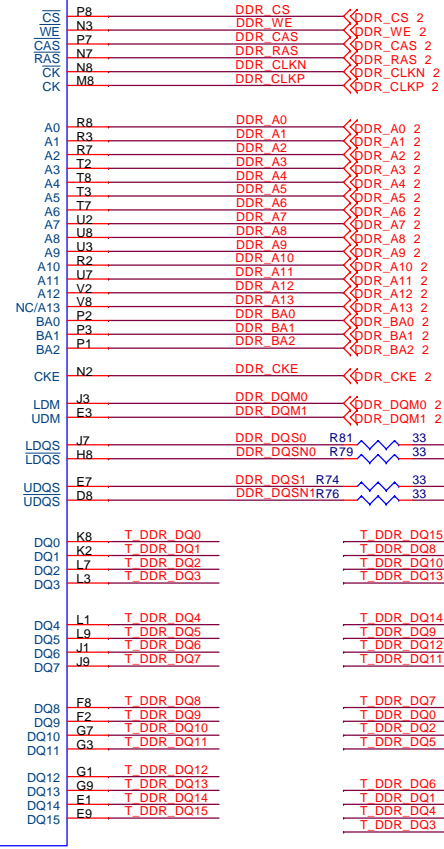
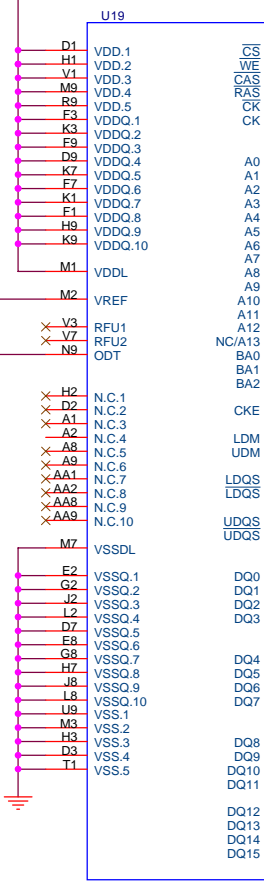
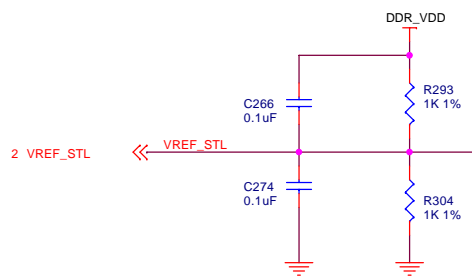
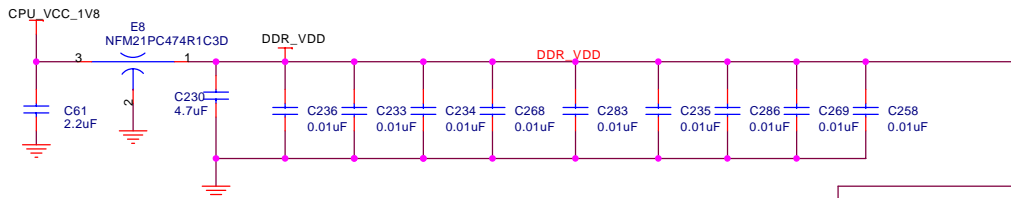

MT47H64M16HR-3:E

Layout for the 92-ball DDR Package but populate the 84-ball MT47H64M16HR-3:E. 84 Ball memories reside in the center section of the 92 Ball Package

SPECTRUM DIGITAL INCORPORATED			
Title: DM365 Evaluation Module			
Page Contents: DDR2 MEMORY			
Size: B	DWG NO	510842-0001	Revision: C
Date:	Monday, April 13, 2009	Sheet 17 of	53

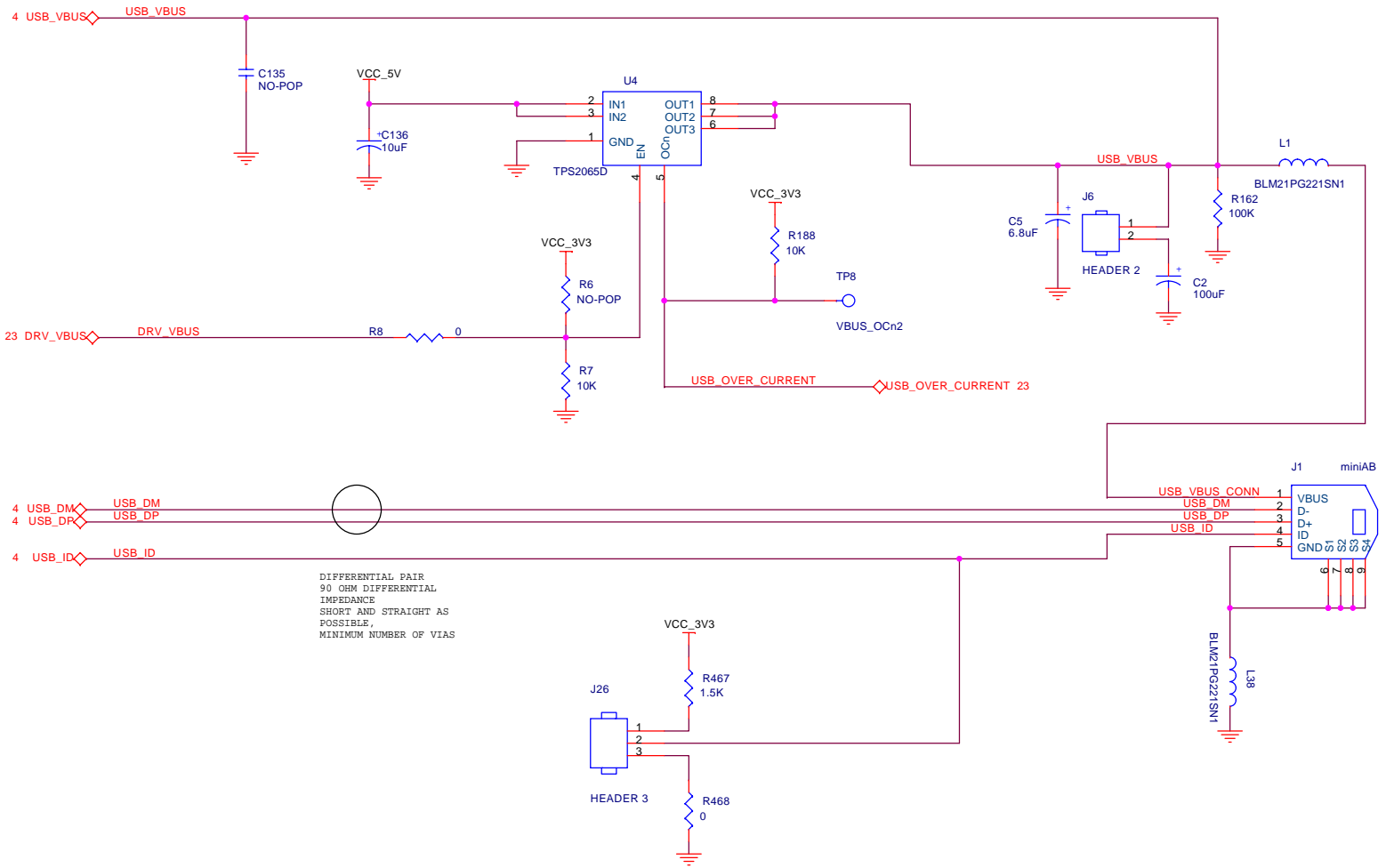

DIFFERENTIAL PAIR
90 OHM DIFFERENTIAL
IMPEDANCE
SHORT AND STRAIGHT AS
POSSIBLE,
MINIMUM NUMBER OF VIAS

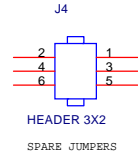

SPECTRUM DIGITAL INCORPORATED			
Title: DM365 Evaluation Module			
Page Contents: DM365 USB			
Size: B	DWG NO	510842-0001	Revision: C
Date:	Monday, April 13, 2009	Sheet 18 of	53

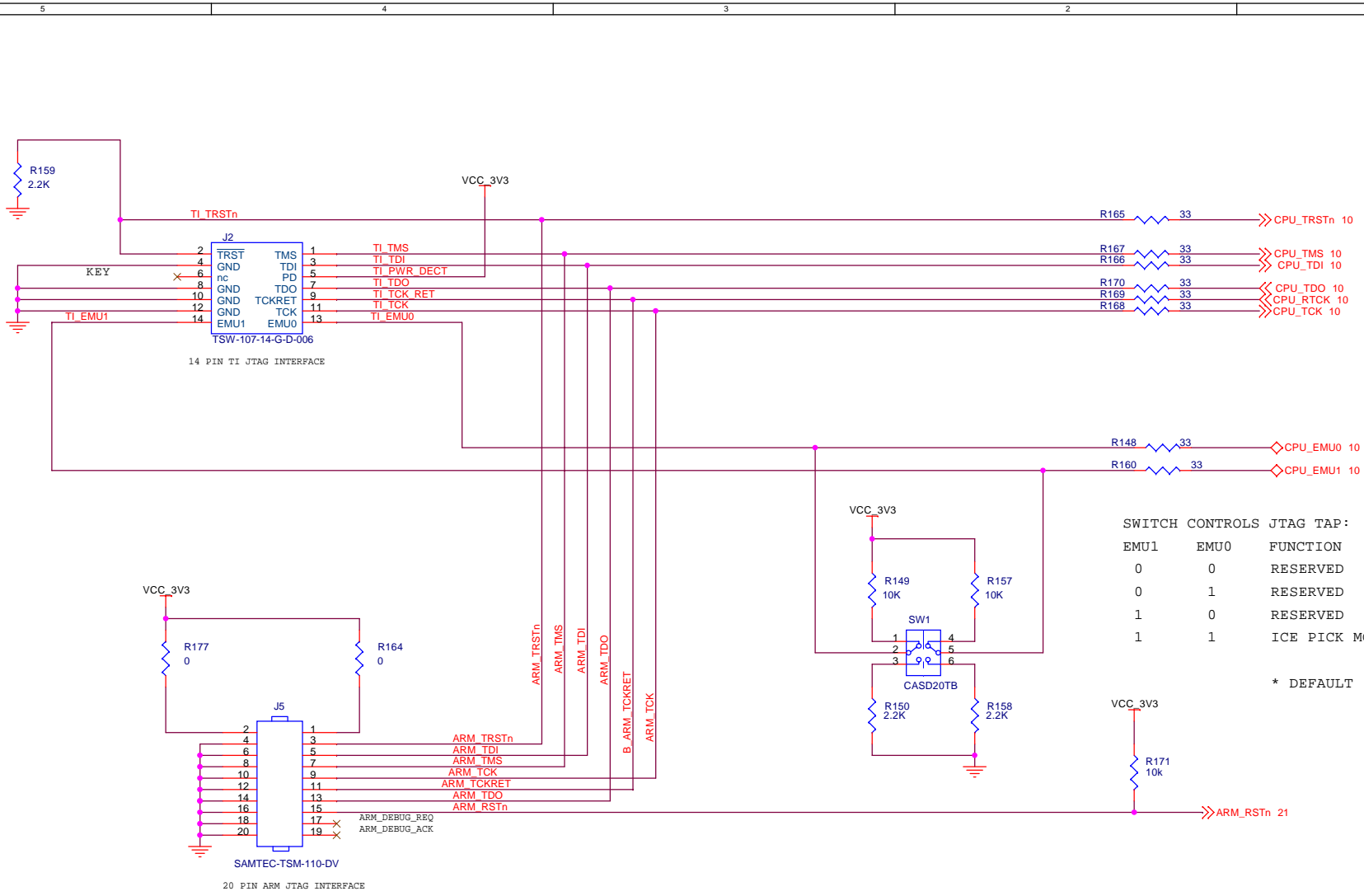

SWITCH CONTROLS JTAG TAP:

EMU1	EMU0	FUNCTION
0	0	RESERVED
0	1	RESERVED
1	0	RESERVED
1	1	ICE PICK MODE *

* DEFAULT

SPECTRUM DIGITAL INCORPORATED			
Title: DM365 Evaluation Module			
Page Contents: JTAG INTERFACE			
Size: B	DWG NO	510842-0001	Revision: C
Date:	Monday, April 13, 2009	Sheet 19 of	53

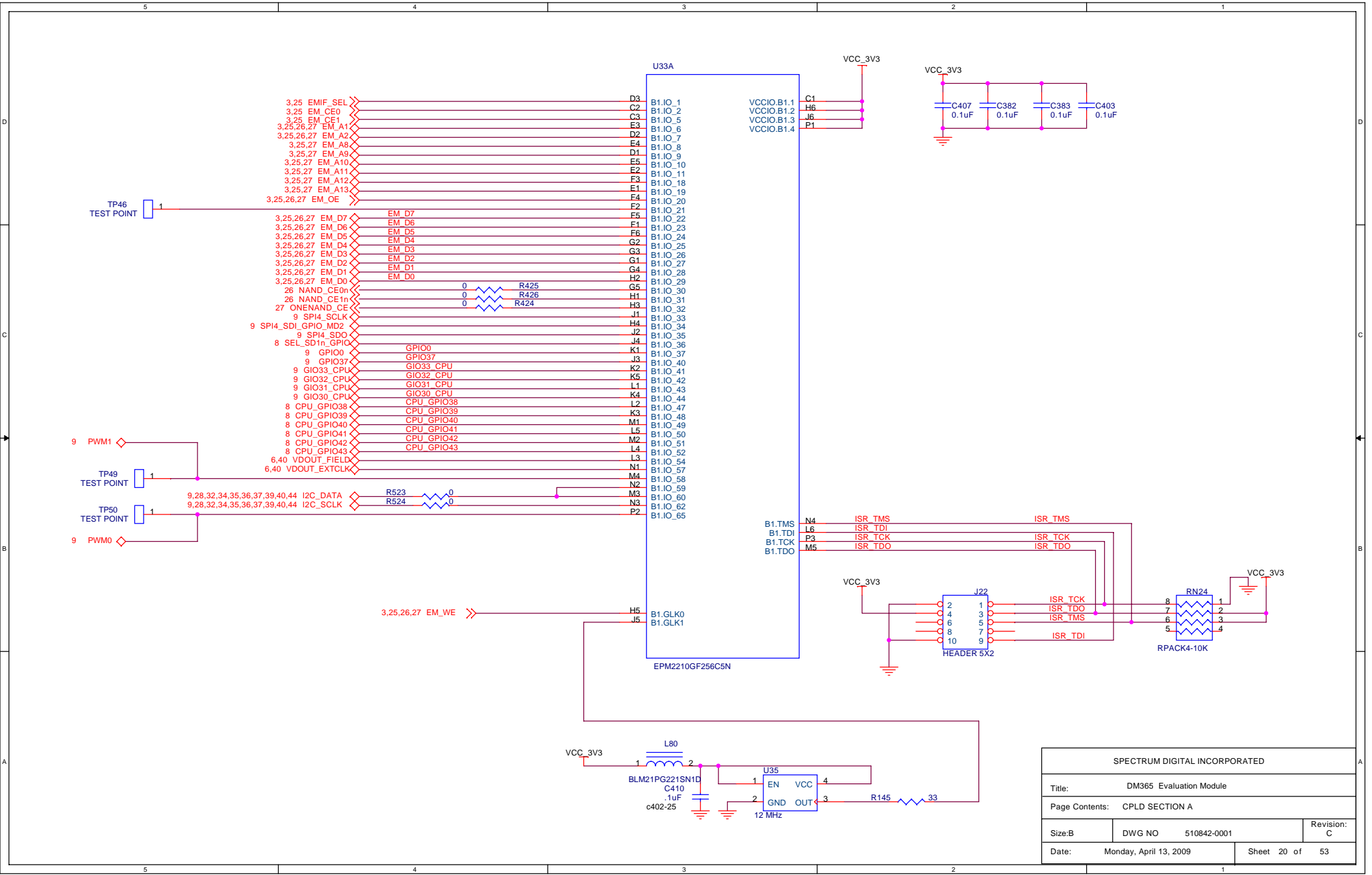

SPECTRUM DIGITAL INCORPORATED			
Title: DM365 Evaluation Module			
Page Contents: CPLD SECTION A			
Size: B	DWG NO	510842-0001	Revision: C
Date:	Monday, April 13, 2009	Sheet 20 of	53

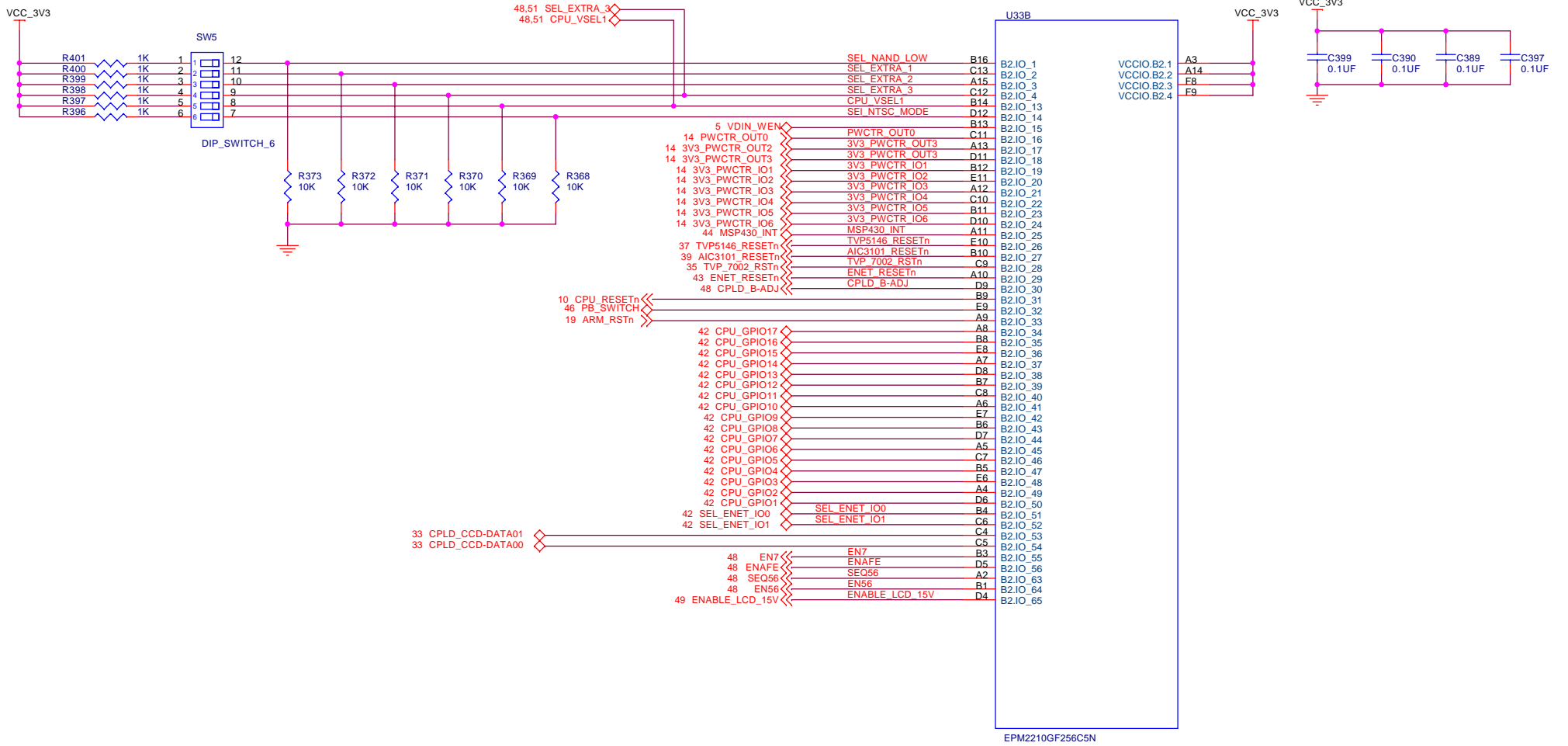

SPECTRUM DIGITAL INCORPORATED			
Title: DM365 Evaluation Module			
Page Contents: CPLD SECTION B			
Size: B	DWG NO	510842-0001	Revision: C
Date:	Monday, April 13, 2009	Sheet	21 of 53

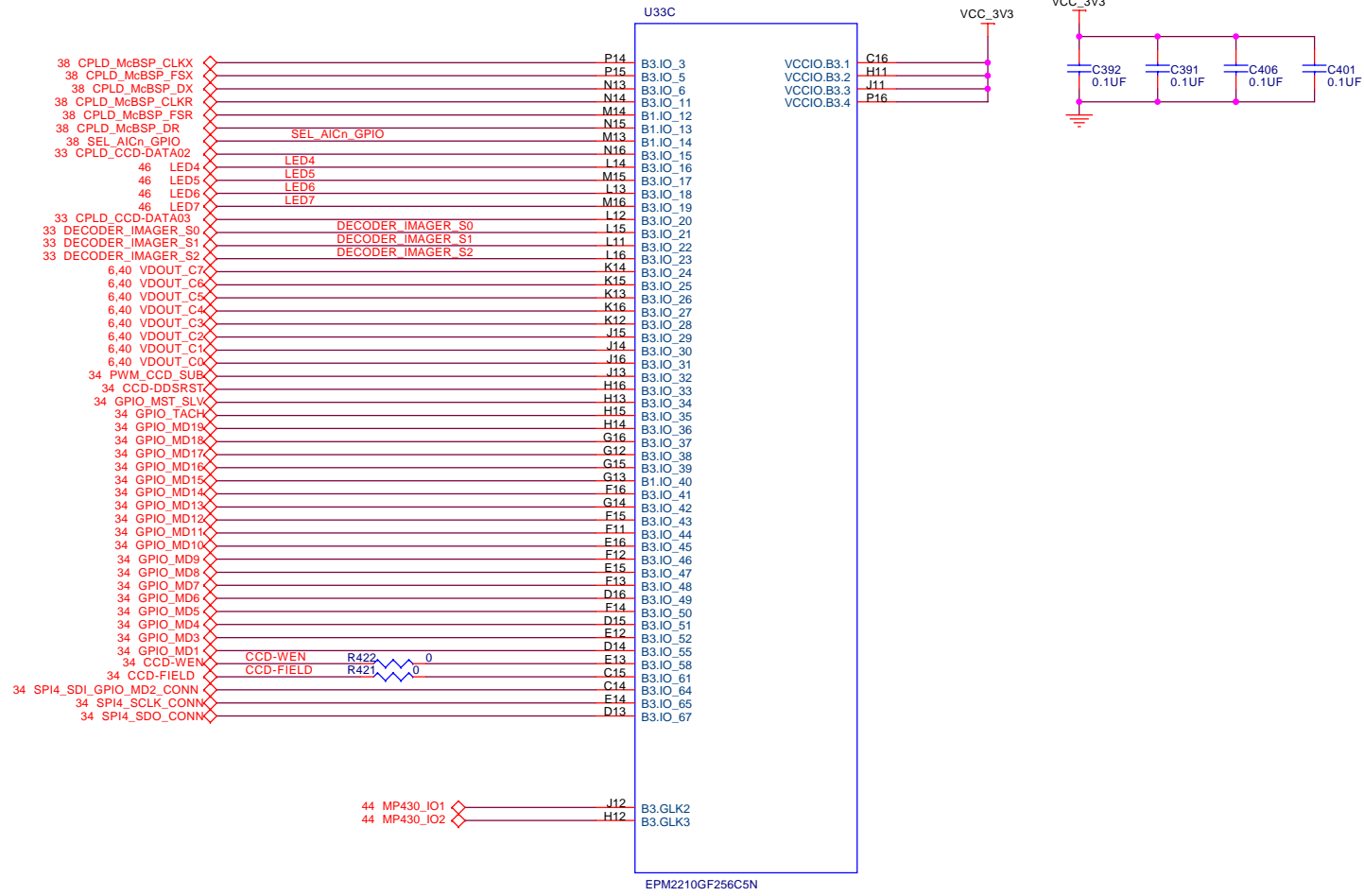

SPECTRUM DIGITAL INCORPORATED			
Title: DM365 Evaluation Module			
Page Contents: CPLD SECTION C			
Size: B	DWG NO	510842-0001	Revision: C
Date:	Monday, April 13, 2009	Sheet 22 of	53

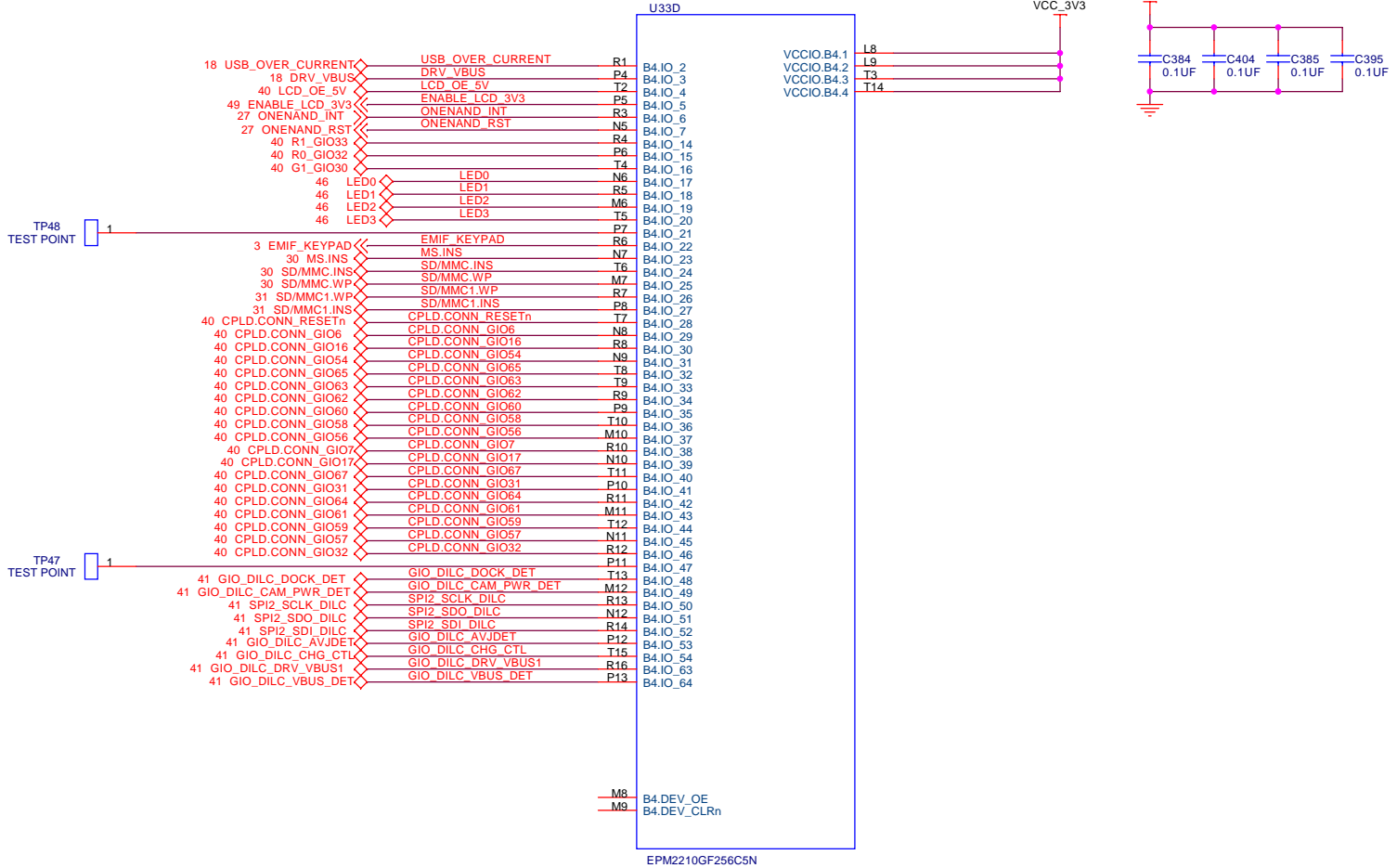

SPECTRUM DIGITAL INCORPORATED			
Title: DM365 Evaluation Module			
Page Contents: CPLD SECTION D			
Size: B	DWG NO	510842-0001	Revision: C
Date:	Monday, April 13, 2009	Sheet 23 of	53

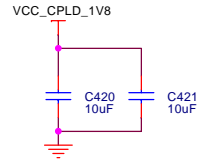
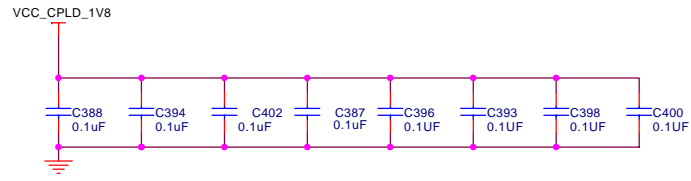
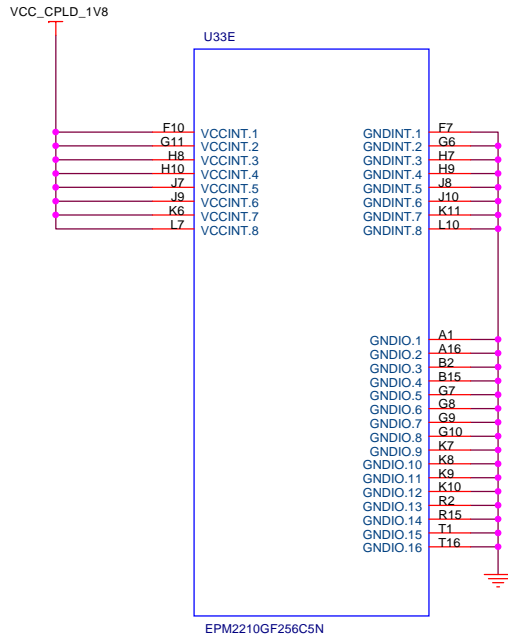

SPECTRUM DIGITAL INCORPORATED			
Title: DM365 Evaluation Module			
Page Contents: CPLD POWER			
Size: B	DWG NO	510842-0001	Revision: C
Date:	Monday, April 13, 2009	Sheet 24 of	53

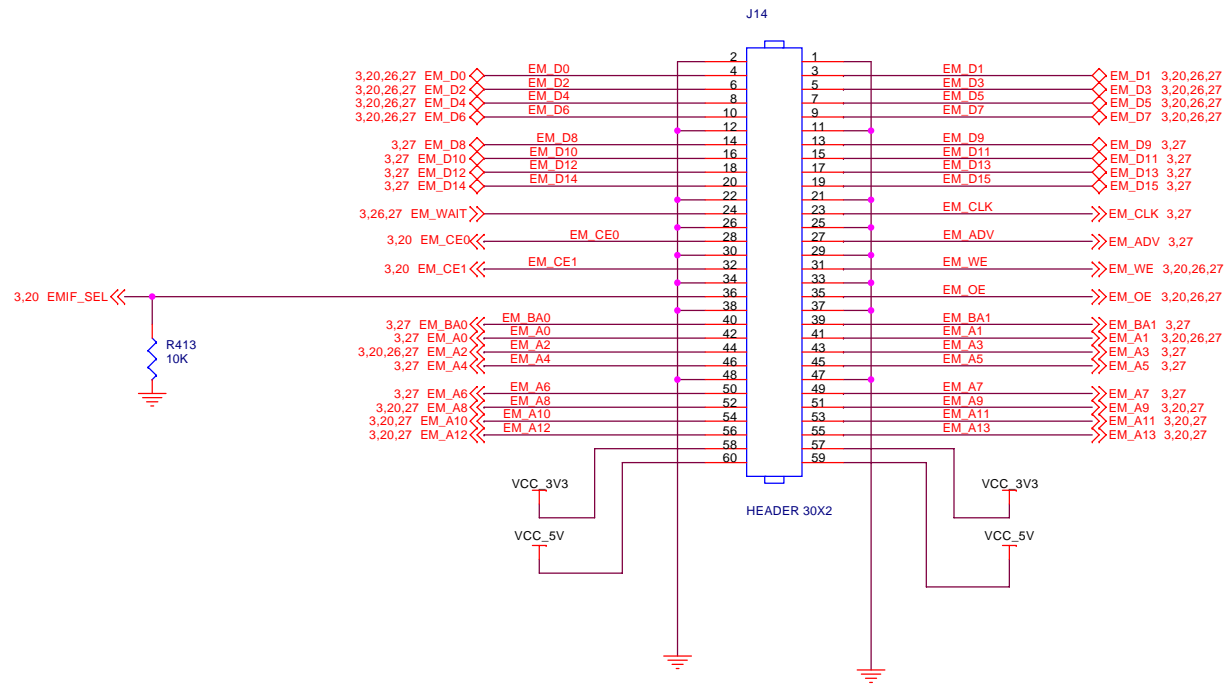

SPECTRUM DIGITAL INCORPORATED			
Title: DM365 Evaluation Module			
Page Contents: EMIF/UHPI DC INTERFACE			
Size: B	DWG NO	510842-0001	Revision: C
Date:	Monday, April 13, 2009		Sheet 25 of 53

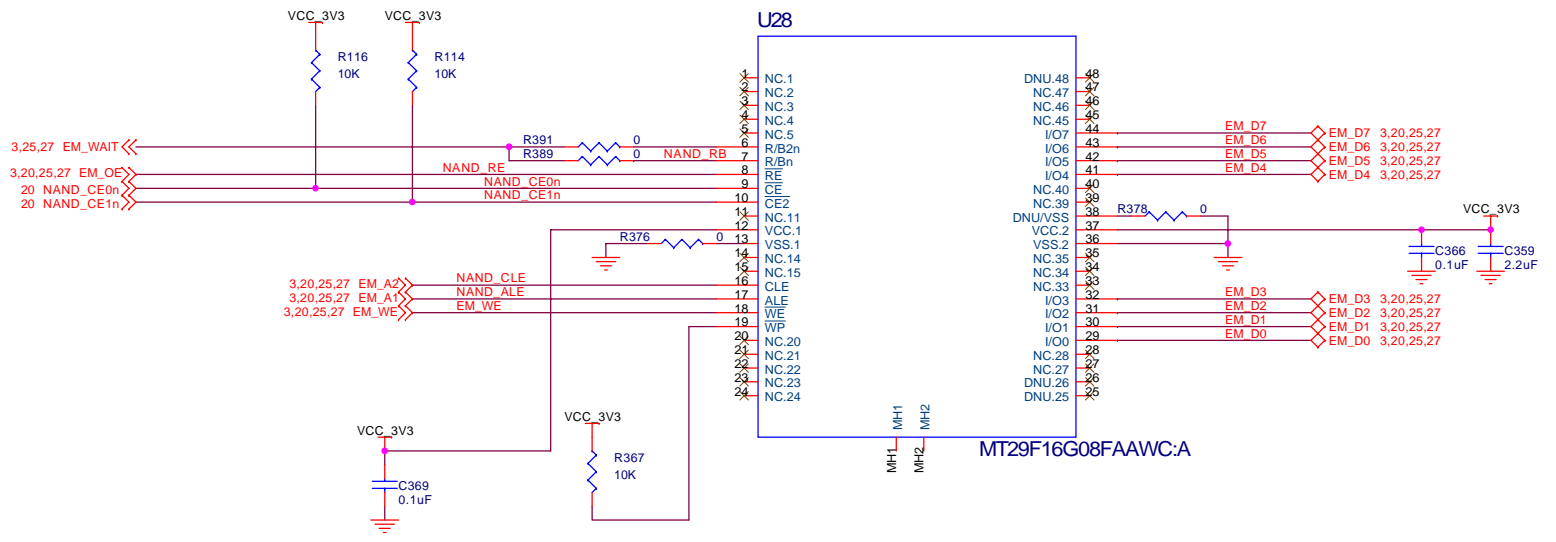

SPECTRUM DIGITAL INCORPORATED			
Title: DM365 Evaluation Module			
Page Contents: NAND FLASH			
Size: B	DWG NO	510842-0001	Revision: C
Date:	Monday, April 13, 2009	Sheet 26 of	53

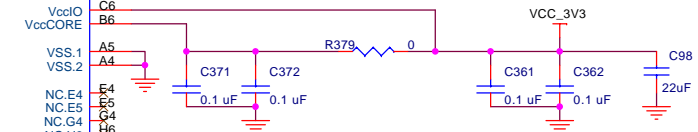
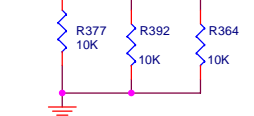
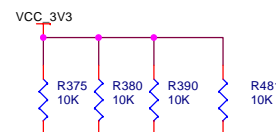
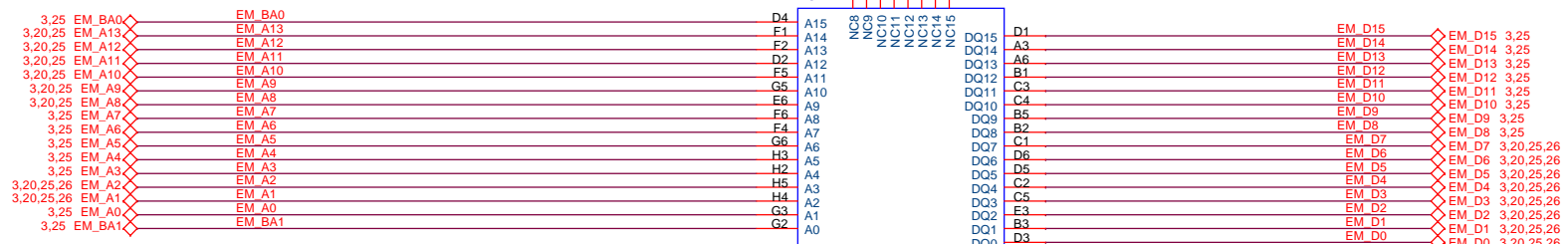

SPECTRUM DIGITAL INCORPORATED			
Title: DM365 Evaluation Module			
Page Contents: ONE NAND			
Size: B	DWG NO	510842-0001	Revision: C
Date:	Monday, April 13, 2009	Sheet 27 of	53

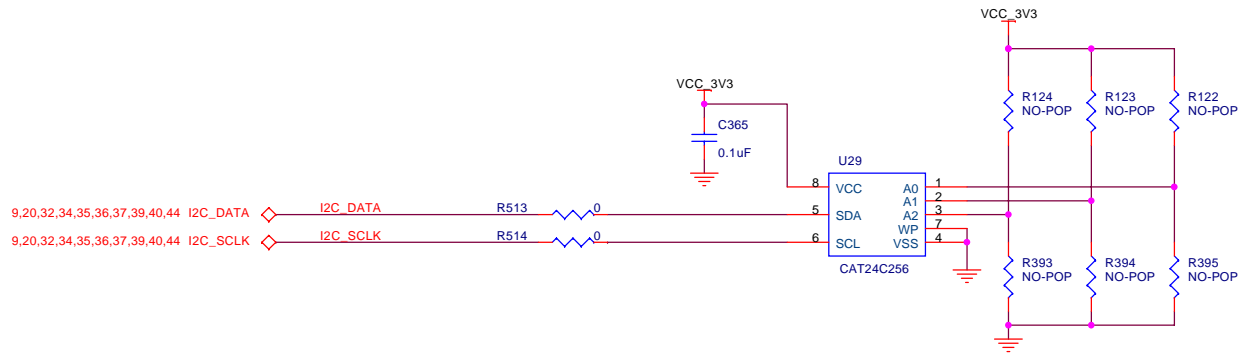
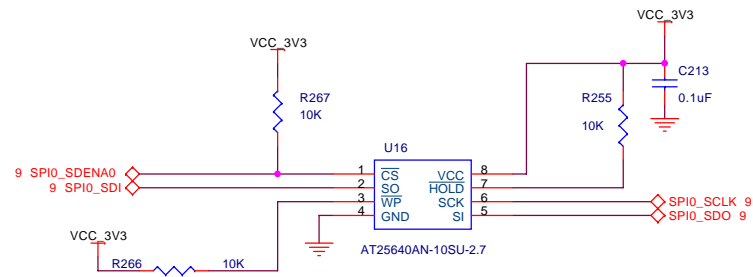

SPECTRUM DIGITAL INCORPORATED			
Title: DM365 Evaluation Module			
Page Contents: SPI EEPROM			
Size: B	DWG NO	510842-0001	Revision: C
Date:	Monday, April 13, 2009	Sheet 28 of	53

5 4 3 2 1

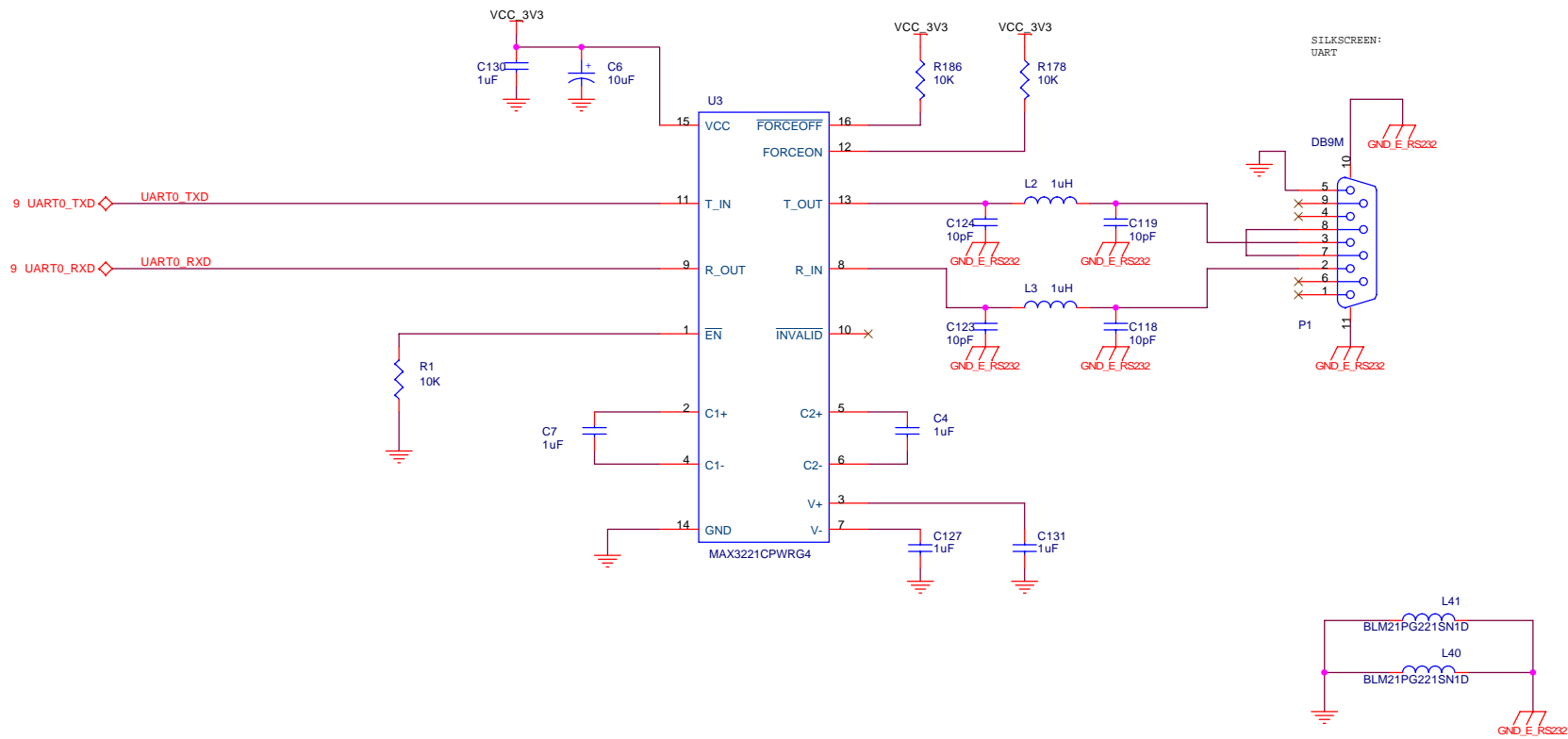

SPECTRUM DIGITAL INCORPORATED			
Title: DM365 Evaluation Module			
Page Contents: RS232			
Size: B	DWG NO	510842-0001	Revision: C
Date:	Monday, April 13, 2009	Sheet 29 of	53

5 4 3 2 1

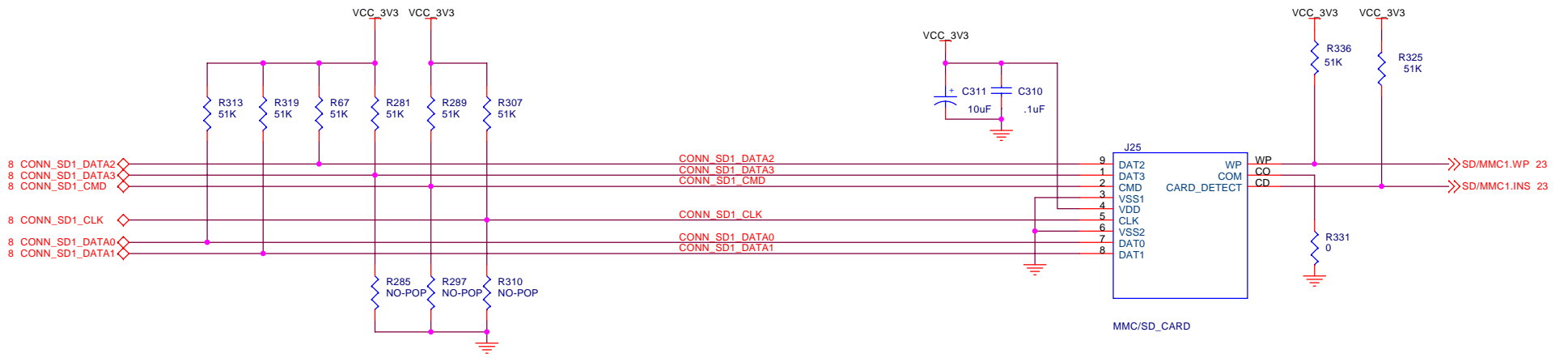

SPECTRUM DIGITAL INCORPORATED		
Title: DM365 Evaluation Module		
Page Contents: SD/MMC CARD INTERFACE		
Size: B	DWG NO: 509902-0001	Revision:
Date: Monday, April 13, 2009	Sheet 31 of 53	

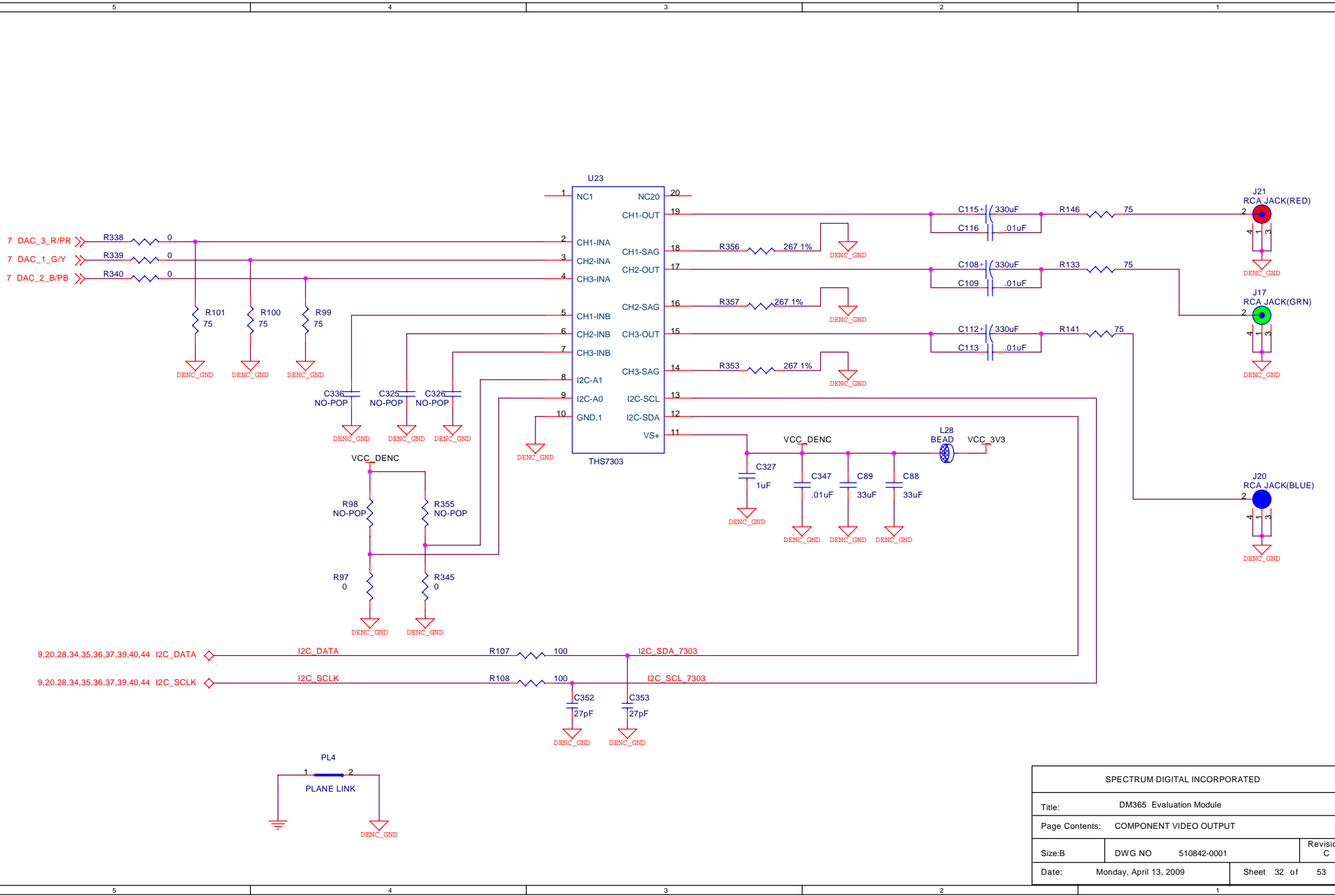

SPECTRUM DIGITAL INCORPORATED			
Title: DM365 Evaluation Module			
Page Contents: COMPONENT VIDEO OUTPUT			
Size: B	DWG NO: 510842-0001	Revision: C	
Date: Monday, April 13, 2009	Sheet 32 of 53		

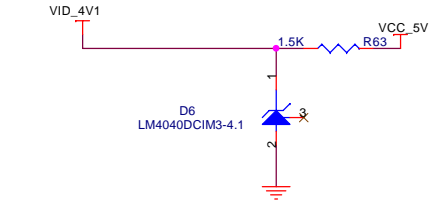
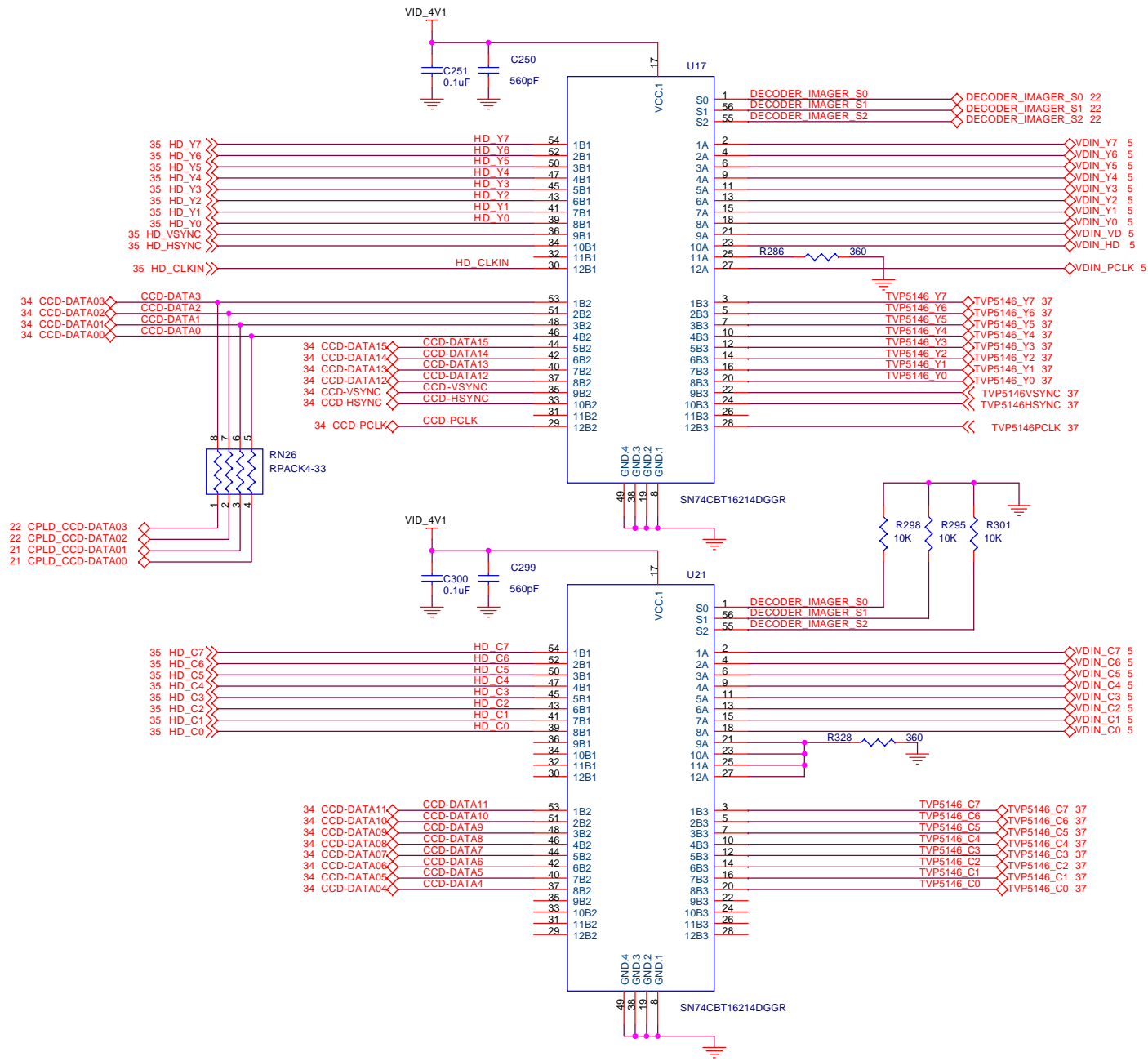

SPECTRUM DIGITAL INCORPORATED			
Title: DM365 Evaluation Module			
Page Contents: VIDEO INPUT MULTIPLEXER			
Size: B	DWG NO	510842-0001	Revision: C
Date:	Monday, April 13, 2009	Sheet 33 of	53

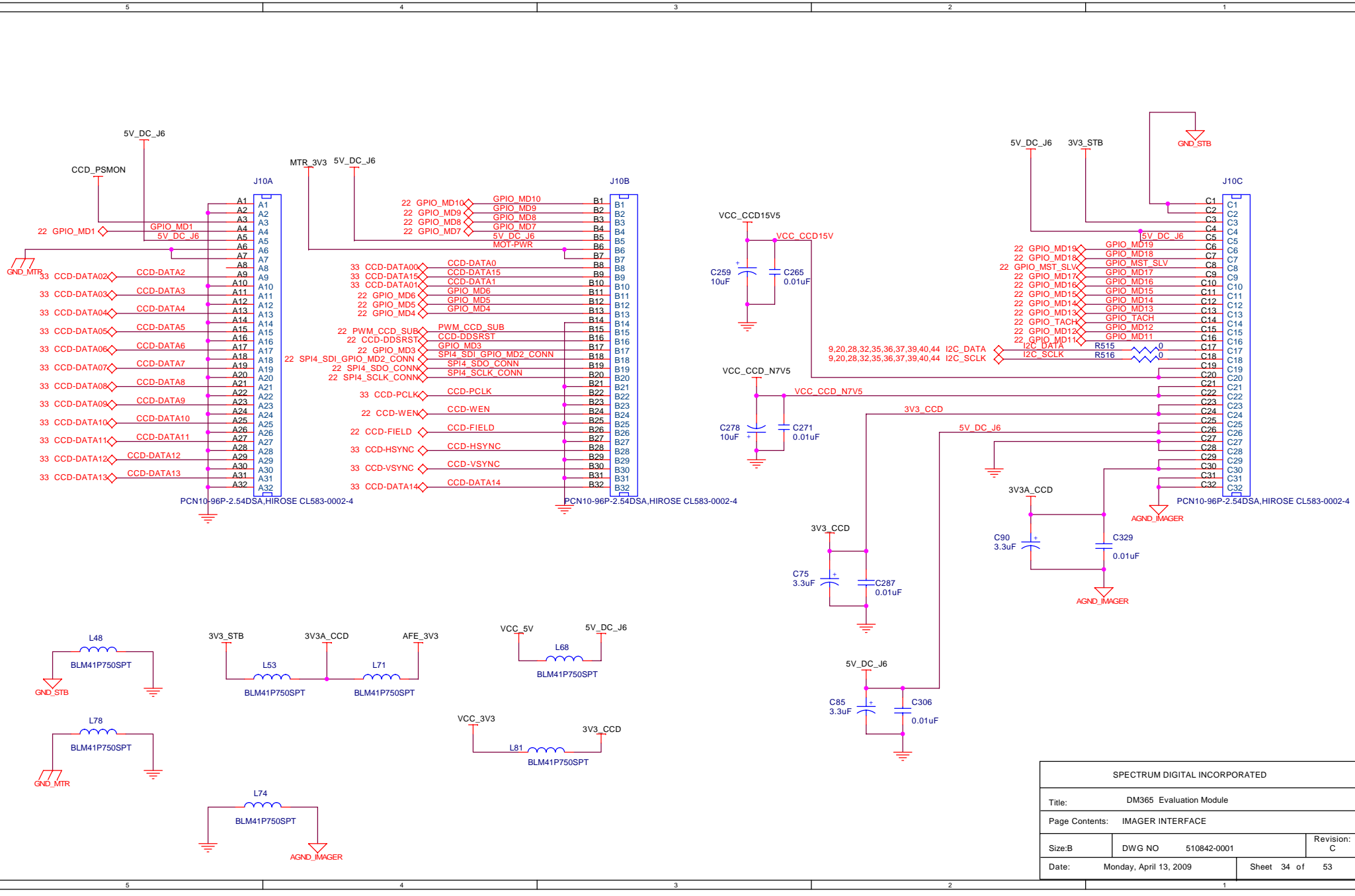

SPECTRUM DIGITAL INCORPORATED			
Title: DM365 Evaluation Module			
Page Contents: IMAGER INTERFACE			
Size: B	DWG NO: 510842-0001	Revision: C	
Date: Monday, April 13, 2009	Sheet 34 of 53		

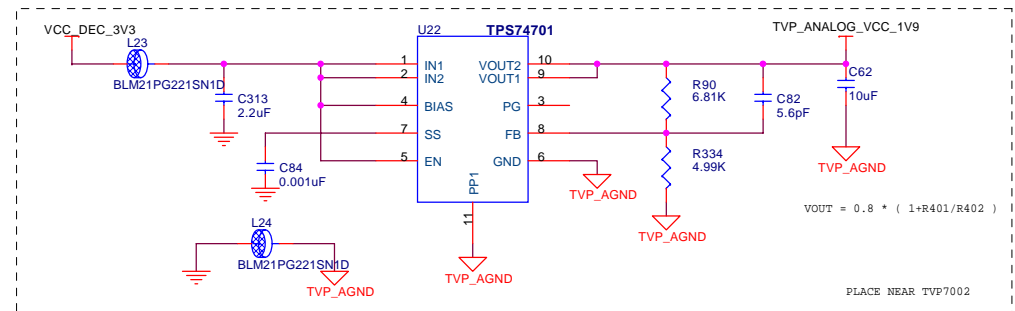
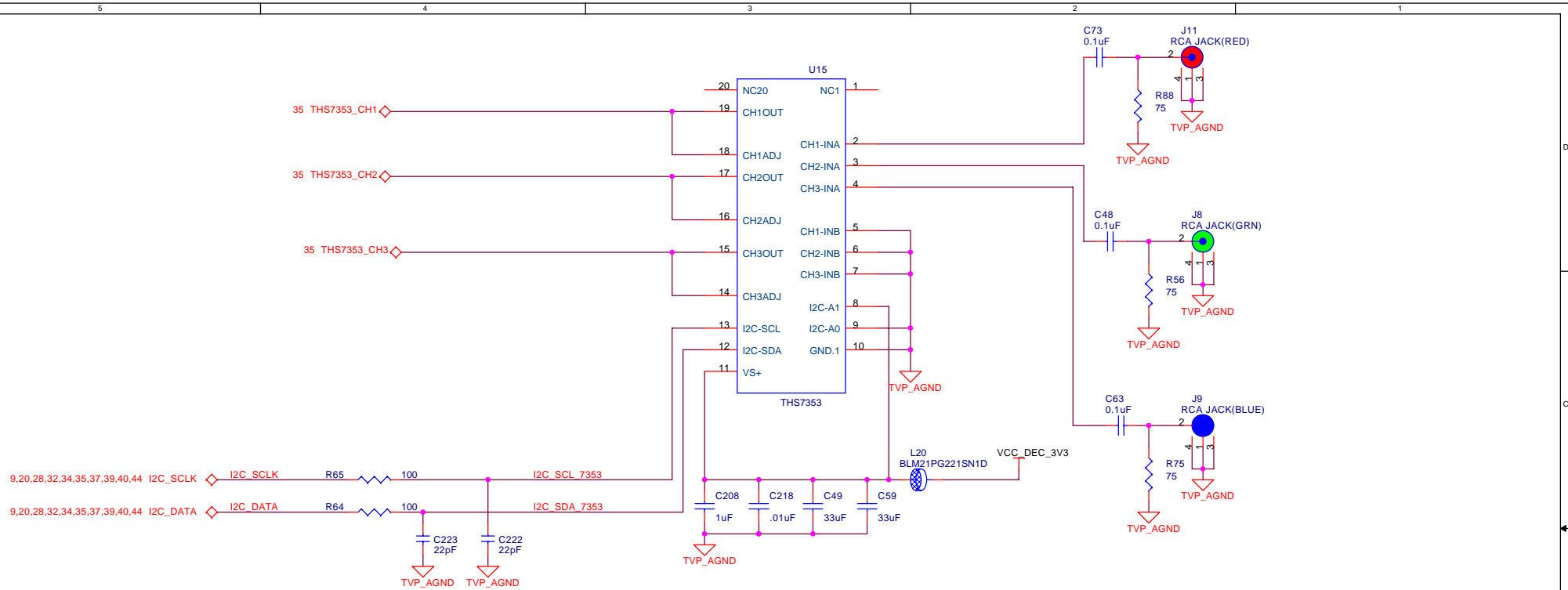

SPECTRUM DIGITAL INCORPORATED			
Title: DM365 Evaluation Module			
Page Contents: TVP7002 HD VIDEO IN			
Size: B	DWG NO	510842-0001	Revision: C
Date:	Monday, April 13, 2009	Sheet 36 of	53

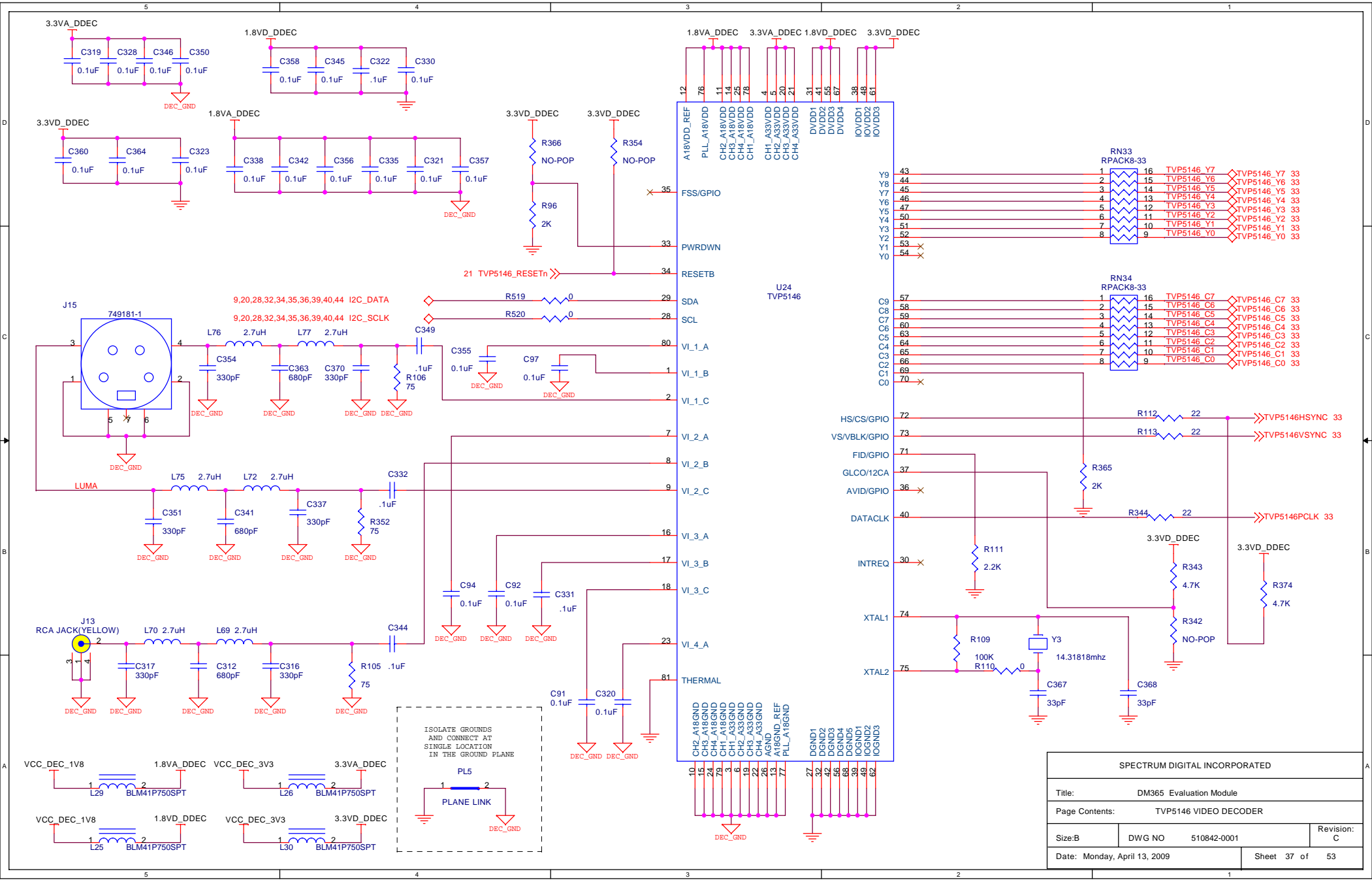

SPECTRUM DIGITAL INCORPORATED			
Title: DM365 Evaluation Module			
Page Contents: TVP5146 VIDEO DECODER			
Size: B	DWG NO: 510842-0001	Revision: C	
Date: Monday, April 13, 2009		Sheet 37 of 53	

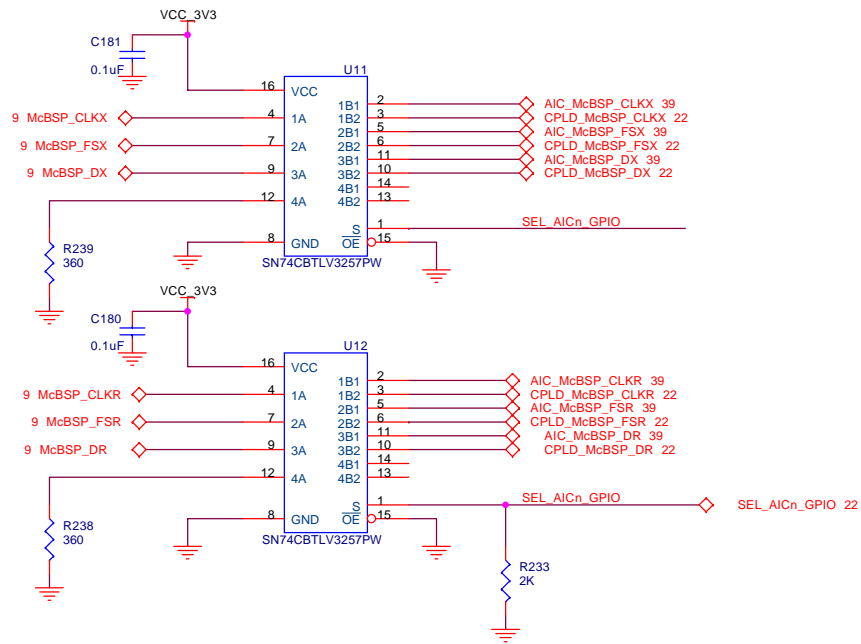

SPECTRUM DIGITAL INCORPORATED			
Title: DM365 Evaluation Module			
Page Contents: McBSP Muxes			
Size: B	DWG NO	510842-0001	Revision: C
Date: Monday, April 13, 2009			Sheet 38 of 53

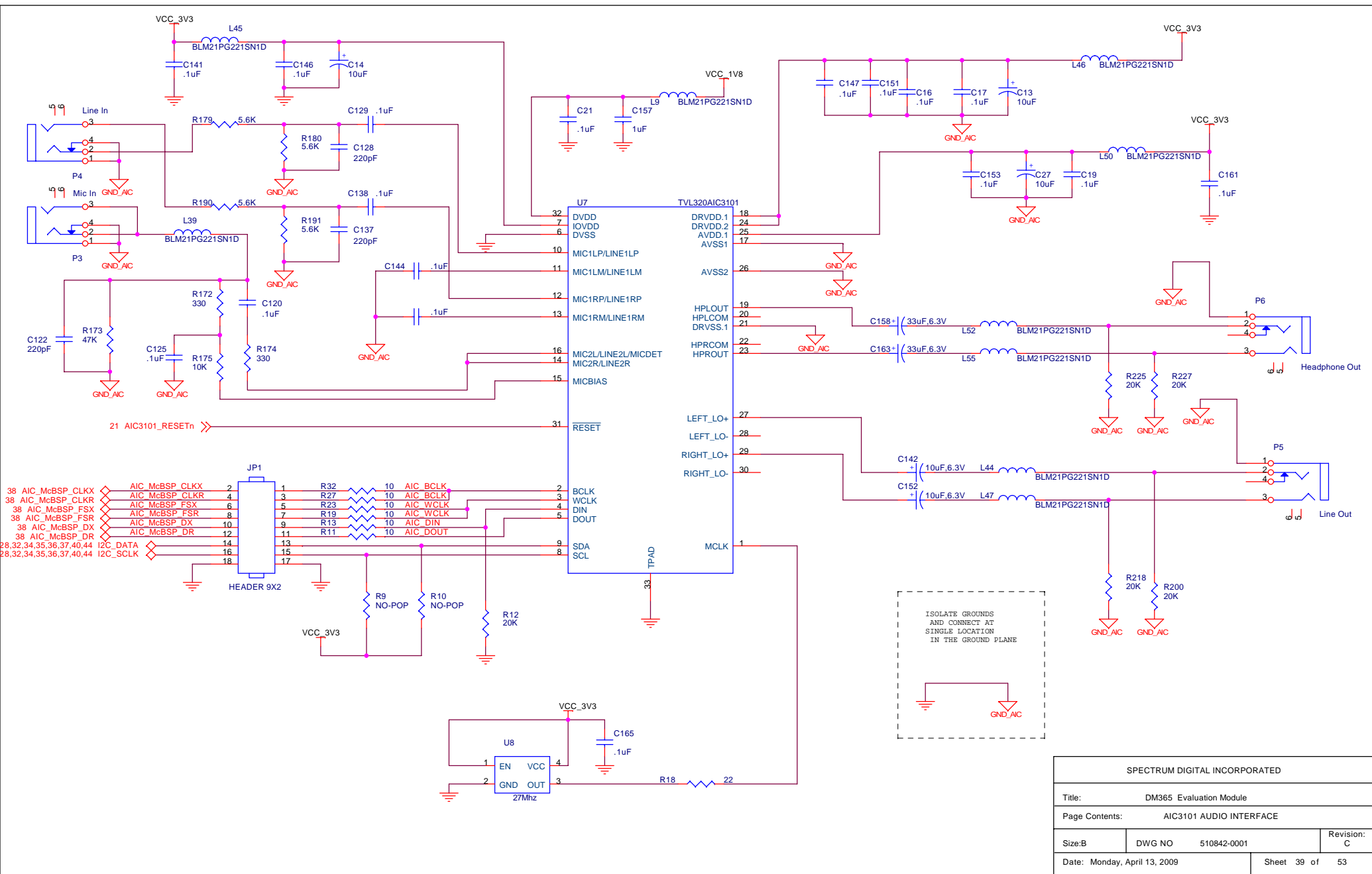

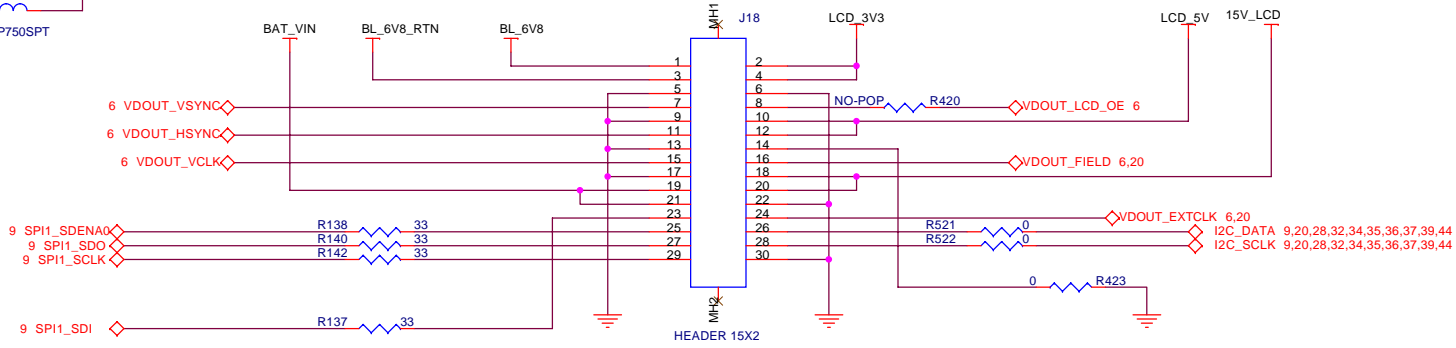
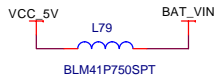
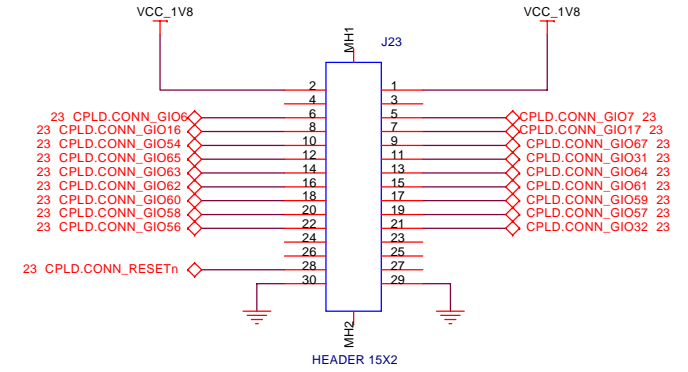
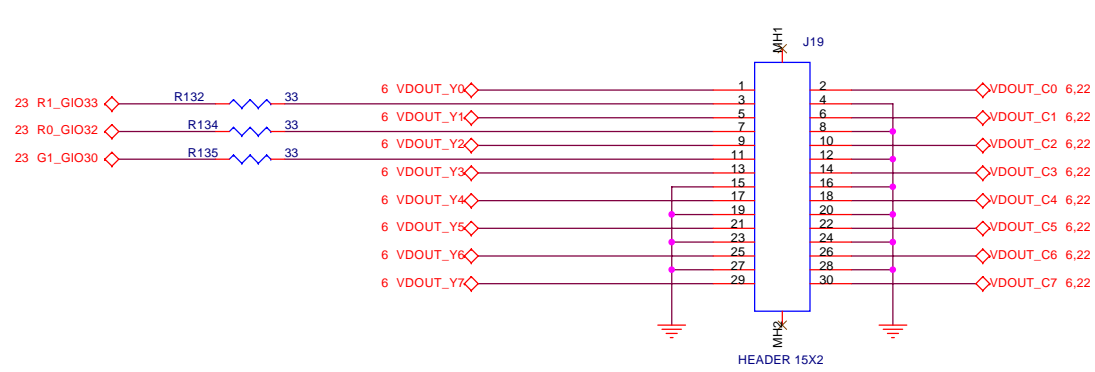

- R0 R1_GIO33
- R1 R1_GIO33
- R2 VDOUT_FIELD
- R3 YOUT3
- R4 YOUT4
- R5 YOUT5
- R6 YOUT6
- R7 YOUT7
- B0 SPI1_SDI
- B1 SPI1_CLK
- B2 VDOUT_VCLK
- B3 COUT0
- B4 COUT1
- B5 COUT2
- B6 COUT3
- B7 COUT4
- G0 SPI1_SDENA0
- G1 G1_GIO30
- G2 COUT5
- G3 COUT6
- G4 COUT7
- G5 YOUT0
- G6 YOUT1
- G7 YOUT2

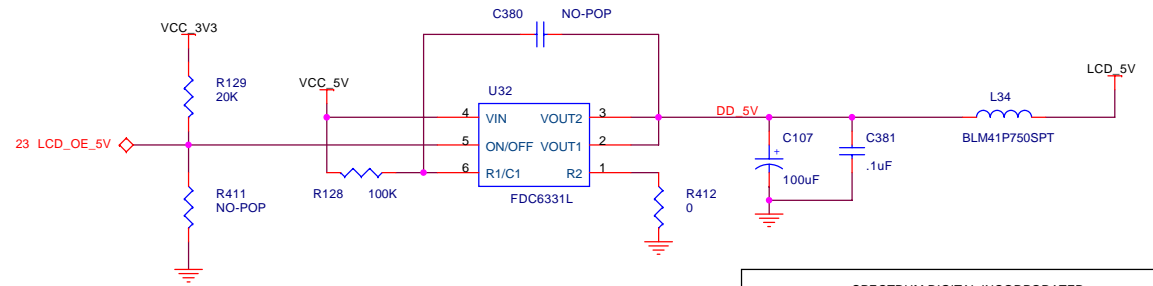

SPECTRUM DIGITAL INCORPORATED			
Title: DM365 Evaluation Module			
Page Contents: VIDEO DAUGHTER CARD OUTPUT			
Size: B	DWG NO	510842-0001	Revision: C
Date: Monday, April 13, 2009			Sheet 40 of 53

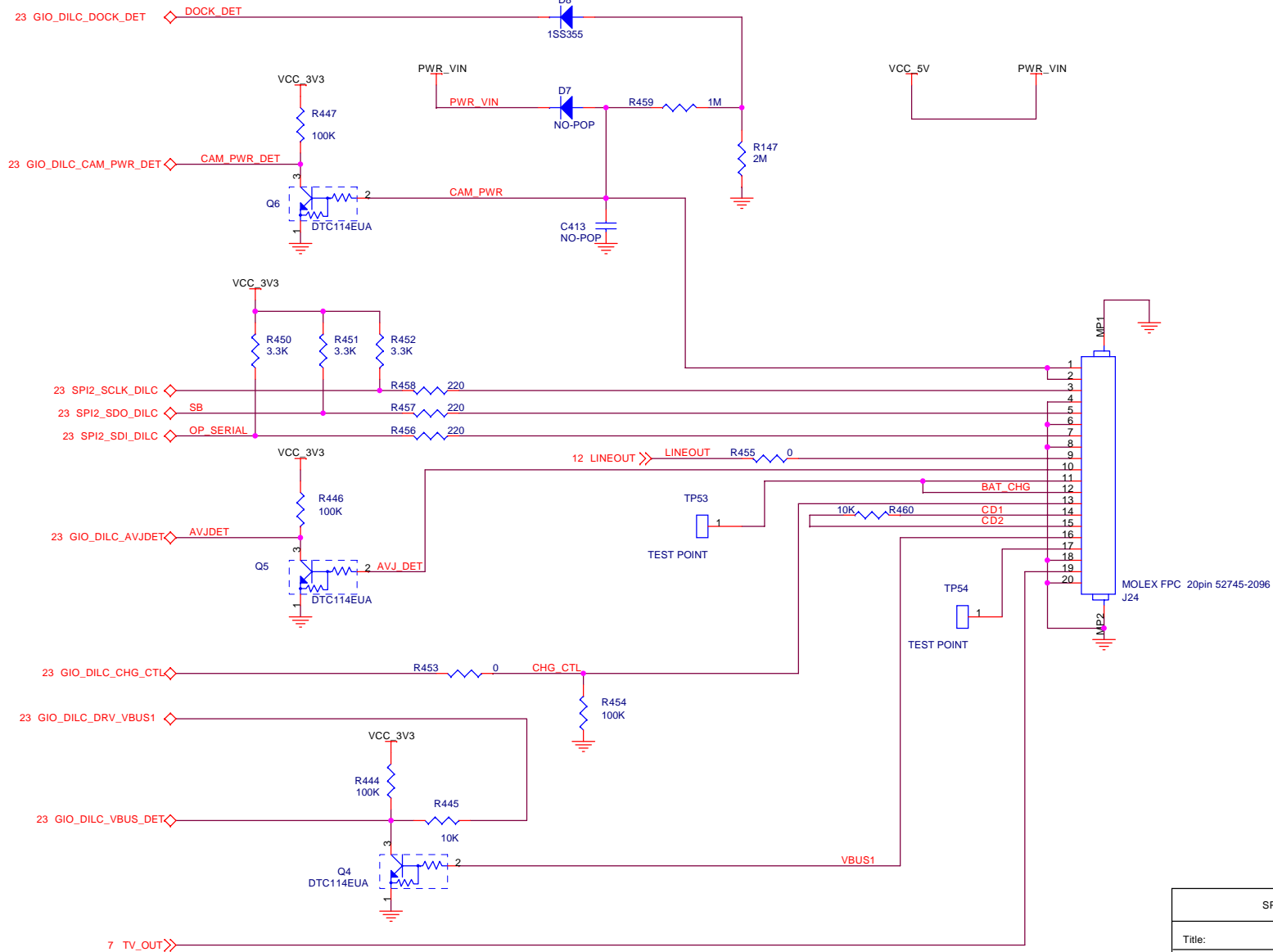

SPECTRUM DIGITAL INCORPORATED			
Title:		DM365 Evaluation Module	
Page Contents:		DILC HOST CONNECTOR	
Size: B	DWG NO	510842-0001	Revision: C
Date: Monday, April 13, 2009		Sheet 41 of 53	

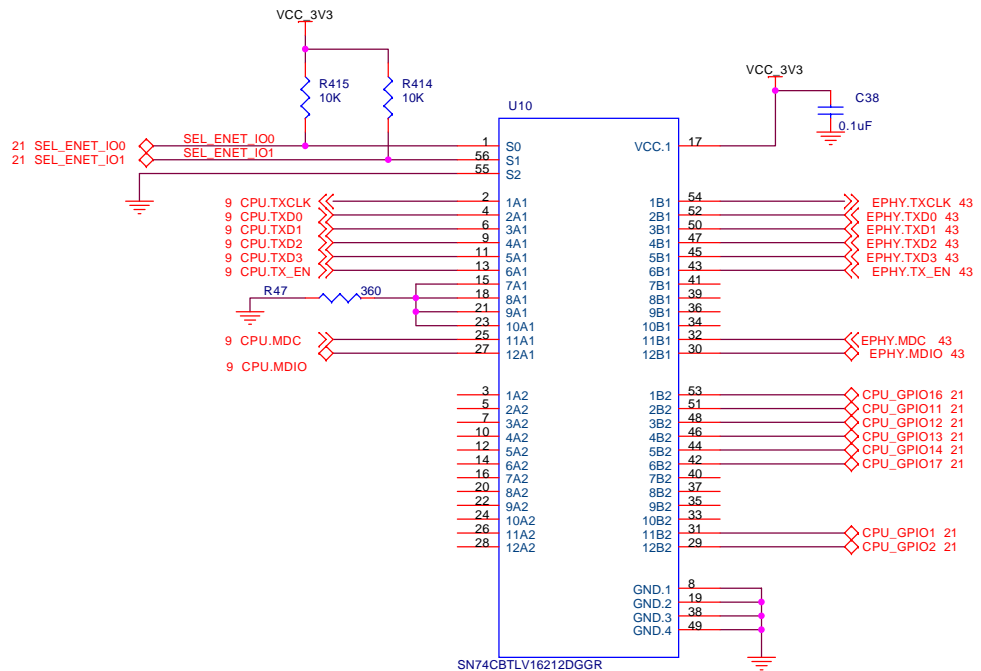

S2	S1	S0	A1	A2	FUNCTION
0	0	0	Z	Z	DISCONNECT
0	0	1	B1	Z	A1 TO B1
0	1	0	B2	Z	A1 TO B2
0	1	1	Z	B1	A2 TO B1
1	0	0	Z	B2	A2 TO B2
1	0	1	Z	Z	DISCONNECT
1	1	0	B1	B2	A1 TO B1 A2 TO B2
1	1	1	B2	B1	A1 TO B2 A2 TO B1

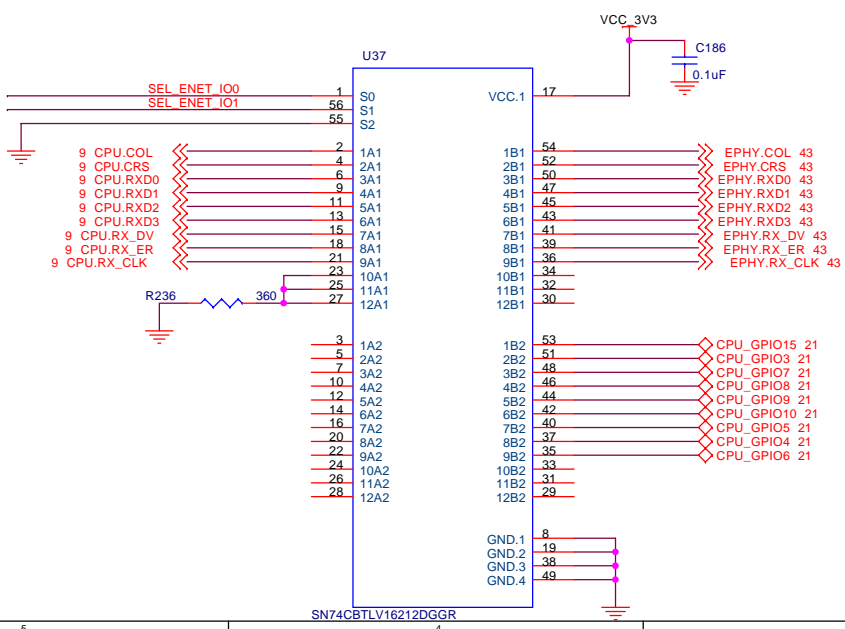

SPECTRUM DIGITAL INCORPORATED			
Title: DM365 Evaluation Module			
Page Contents: ETHERNET MUXES			
Size: B	DWG NO	510842-0001	Revision: C
Date:	Monday, April 13, 2009	Sheet 42 of	53

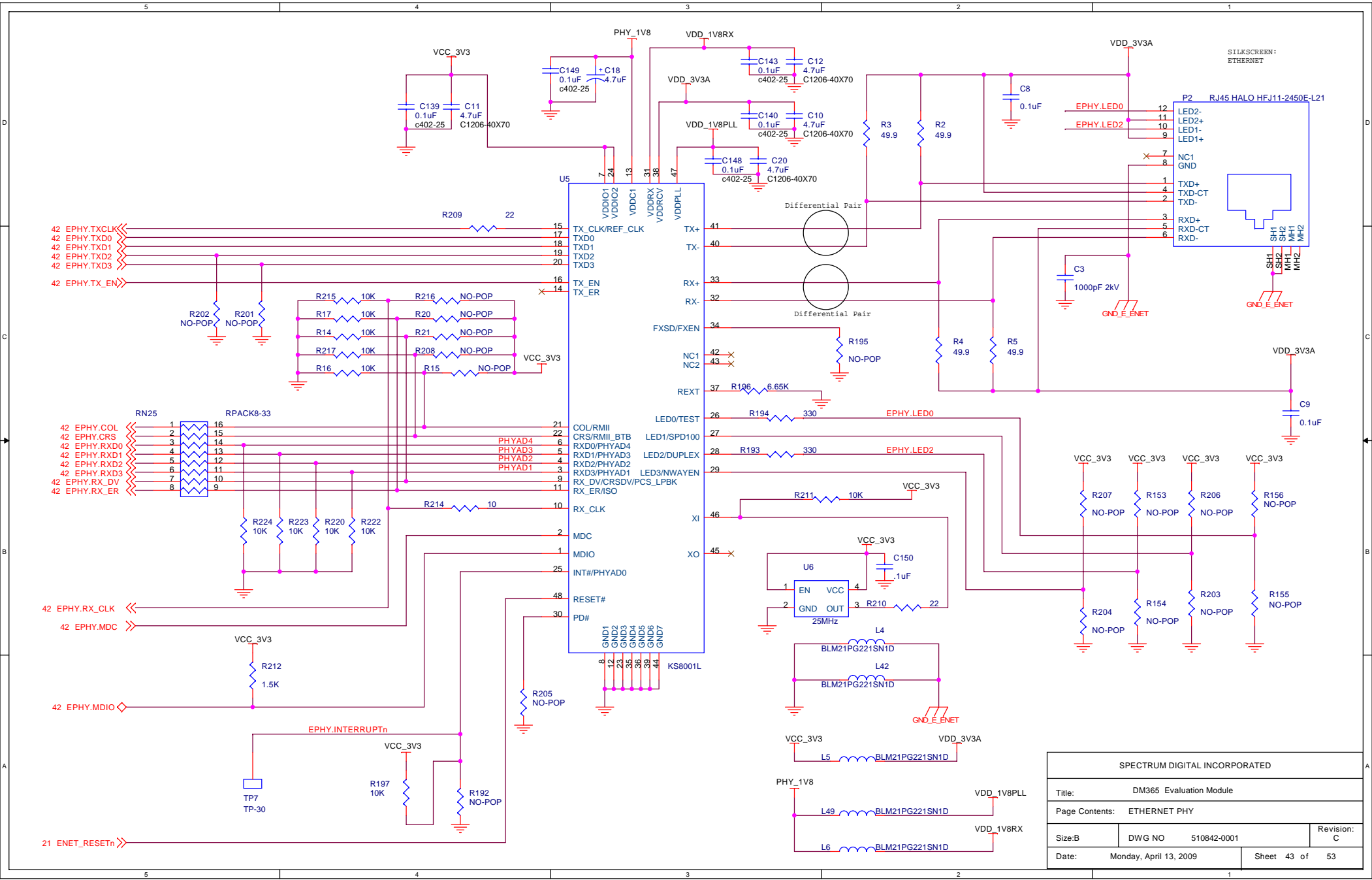

SPECTRUM DIGITAL INCORPORATED			
Title: DM365 Evaluation Module			
Page Contents: ETHERNET PHY			
Size: B	DWG NO	510842-0001	Revision: C
Date:	Monday, April 13, 2009	Sheet 43 of	53

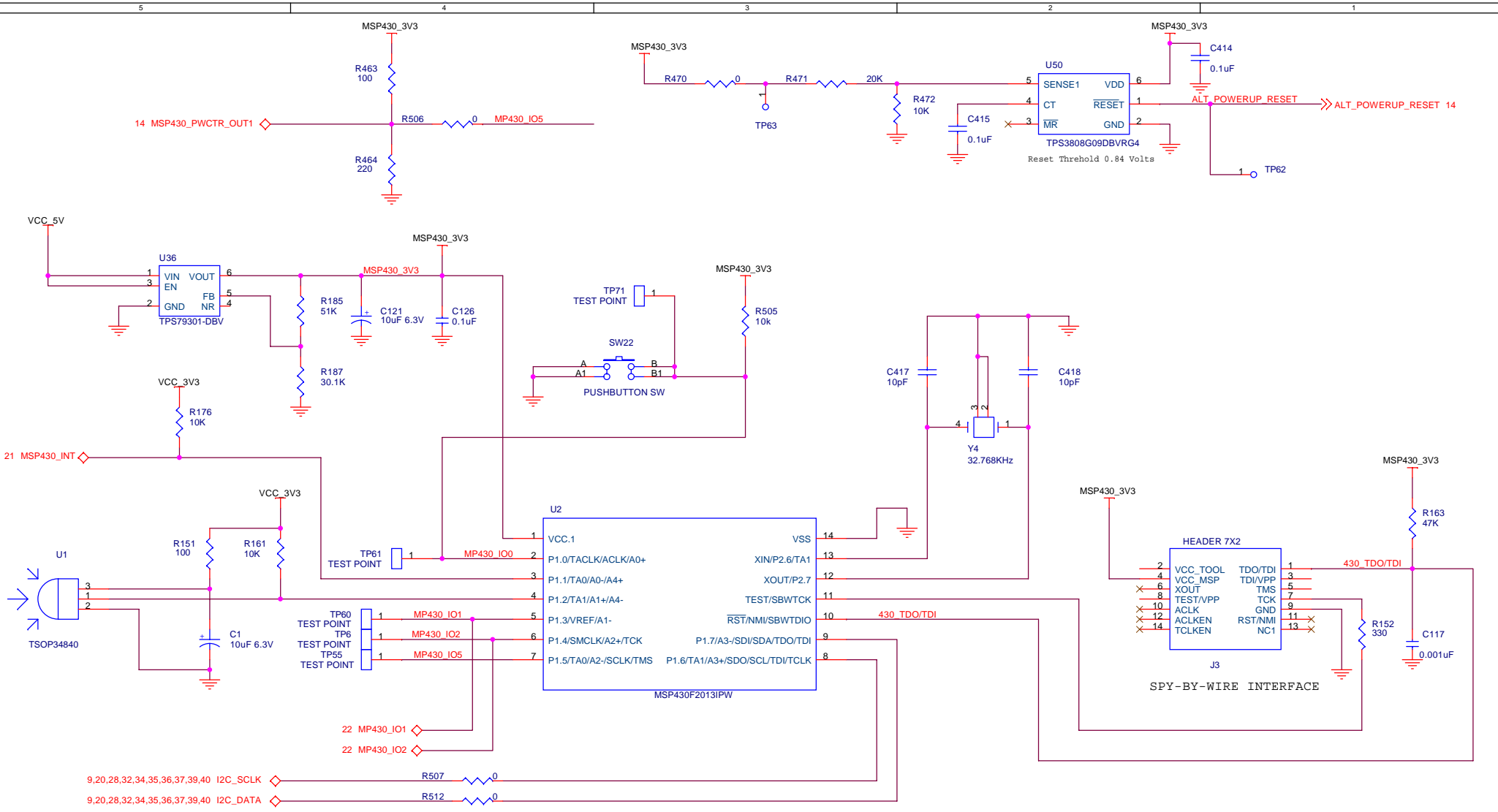

SPECTRUM DIGITAL INCORPORATED			
Title: DM365 Evaluation Module			
Page Contents: MSP430 & IR INTERFACE			
Size: B	DWG NO	510842-0001	Revision: C
Date:	Monday, April 13, 2009	Sheet 44 of	53

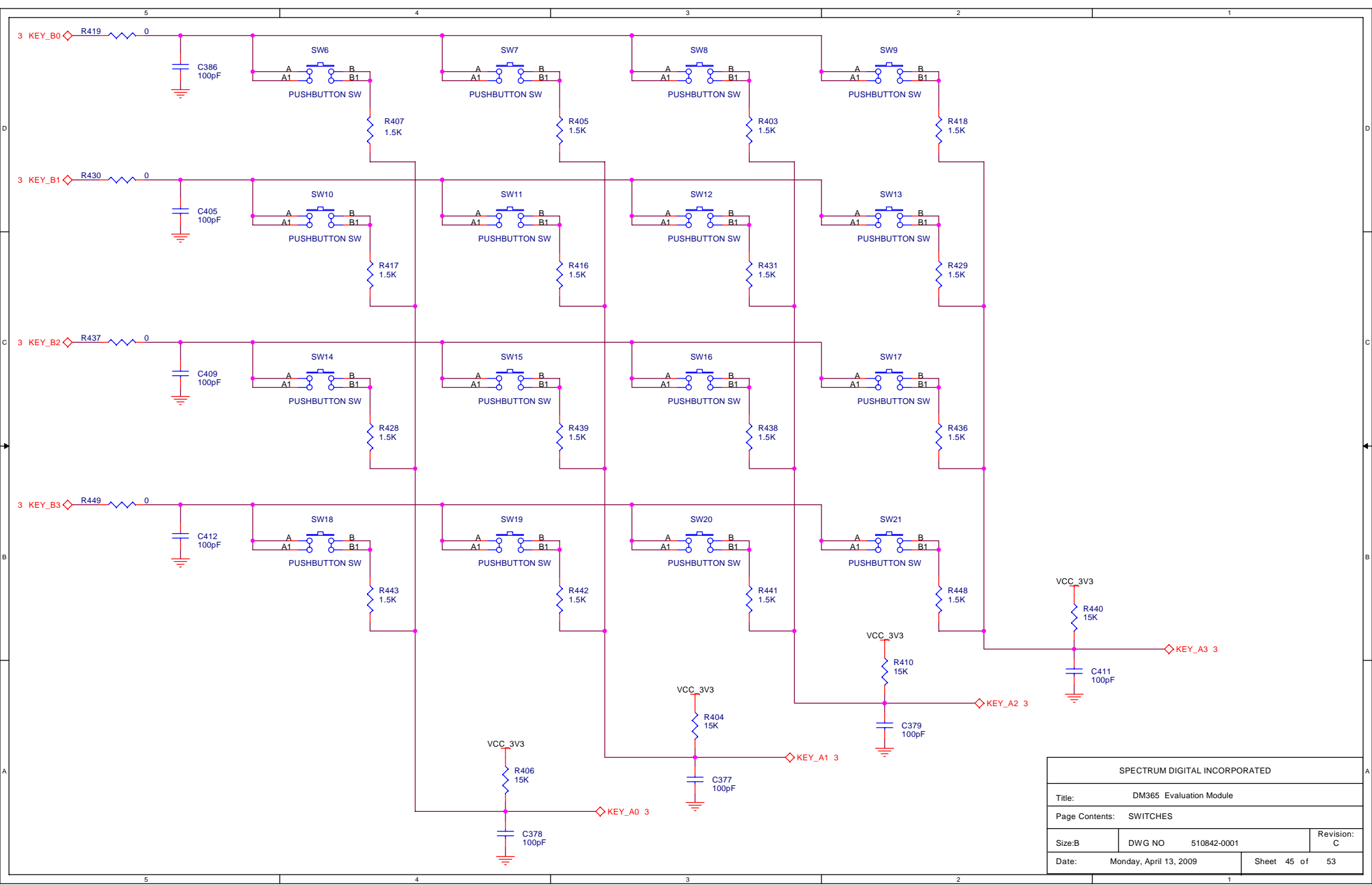

SPECTRUM DIGITAL INCORPORATED			
Title: DM365 Evaluation Module			
Page Contents: SWITCHES			
Size: B	DWG NO	510842-0001	Revision: C
Date:	Monday, April 13, 2009		Sheet 45 of 53

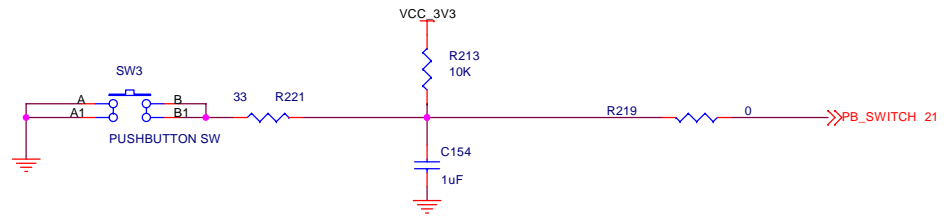
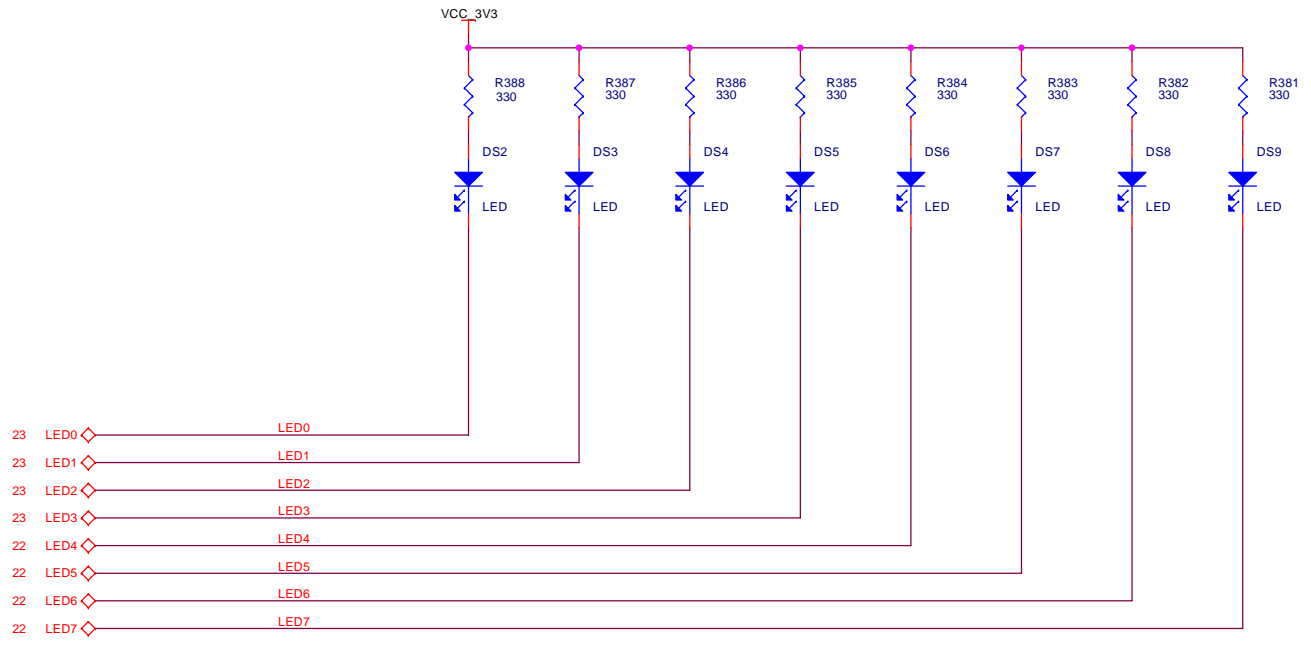

SPECTRUM DIGITAL INCORPORATED			
Title: DM365 Evaluation Module			
Page Contents: LEDS			
Size: B	DWG NO	510842-0001	Revision: C
Date:	Monday, April 13, 2009		Sheet 46 of 53

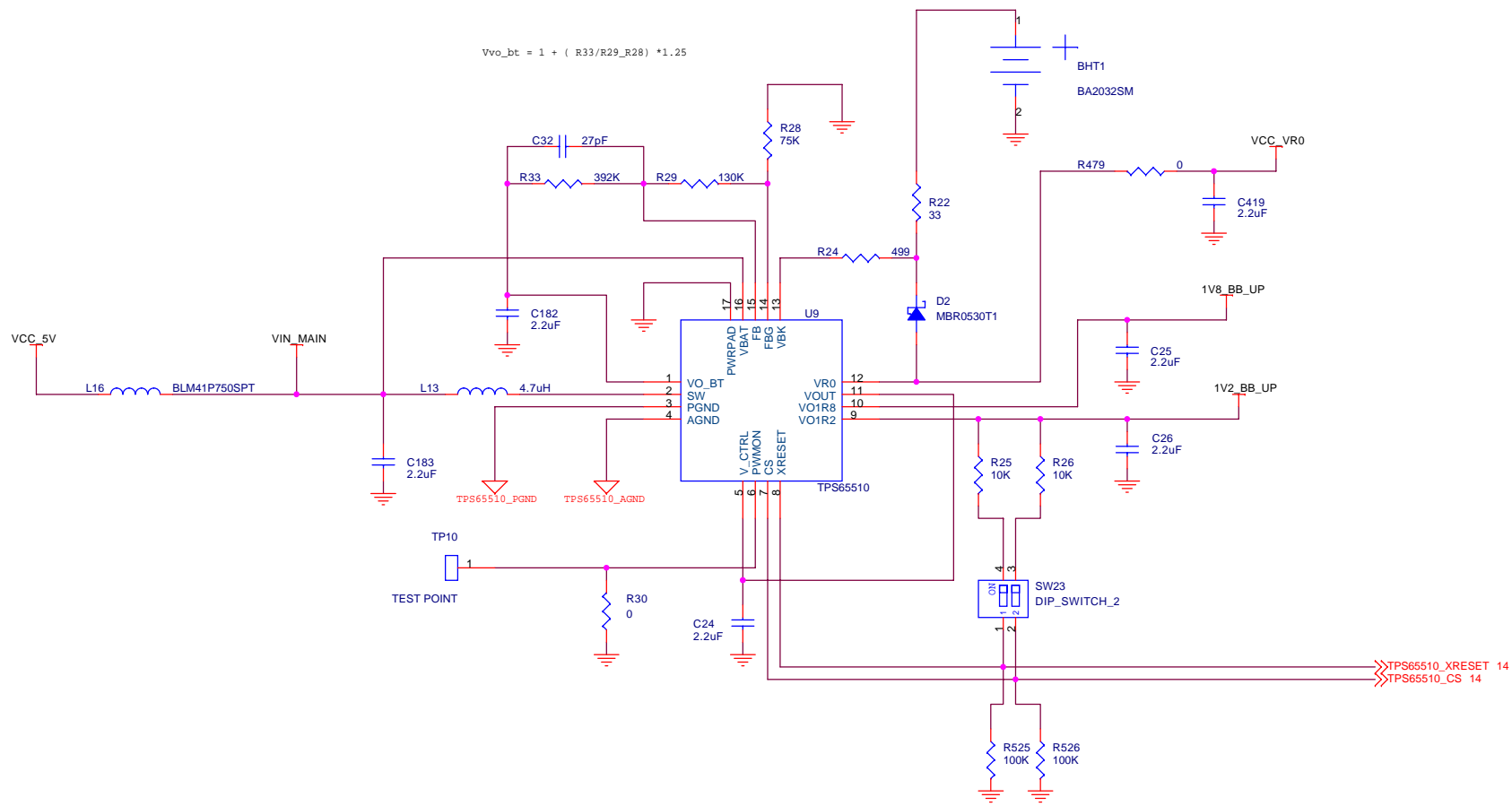

$$Vvo_bt = 1 + (R33/R29_R28) * 1.25$$

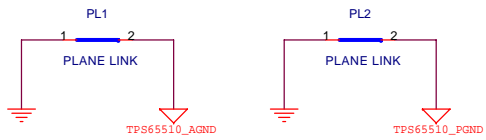

SPECTRUM DIGITAL INCORPORATED			
Title: DM365 Evaluation Module			
Page Contents: POWER SUPPLY TPS65510			
Size: B	DWG NO	510842-0001	Revision: C
Date:	Monday, April 13, 2009	Sheet 47 of	53

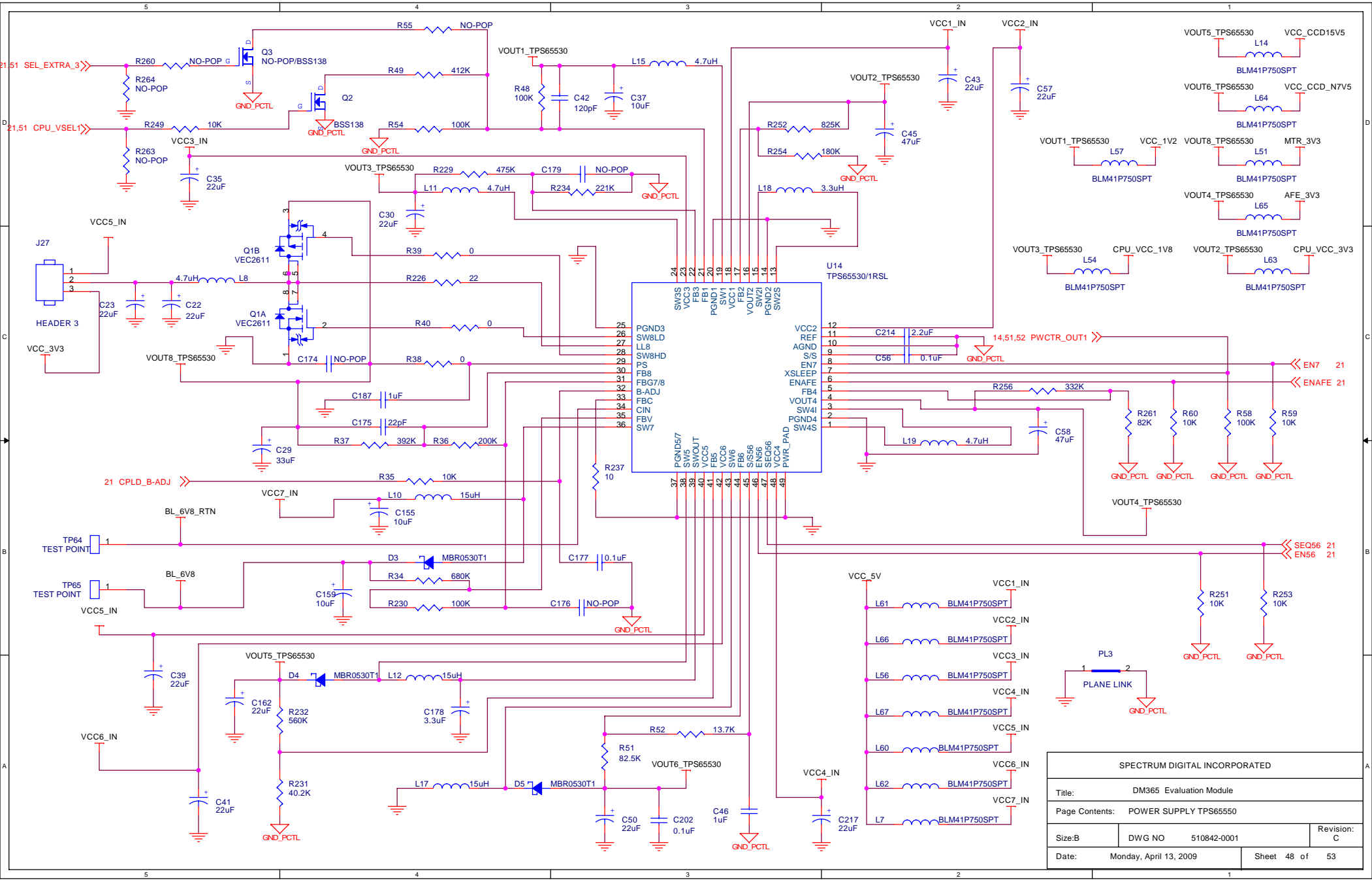

SPECTRUM DIGITAL INCORPORATED			
Title: DM365 Evaluation Module			
Page Contents: POWER SUPPLY TPS65530			
Size: B	DWG NO: 510842-0001	Revision: C	
Date: Monday, April 13, 2009	Sheet 48 of 53		

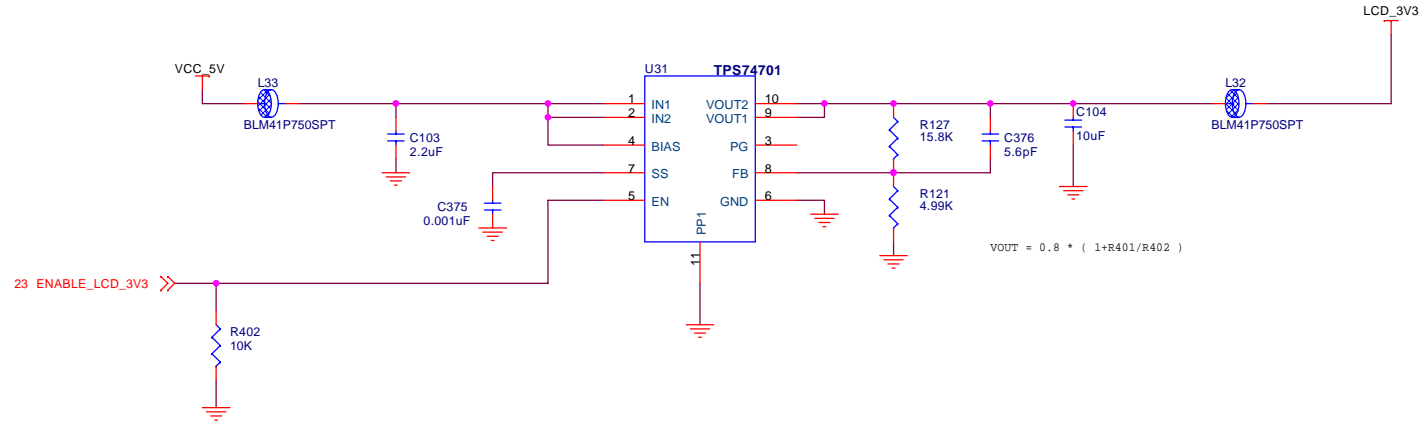
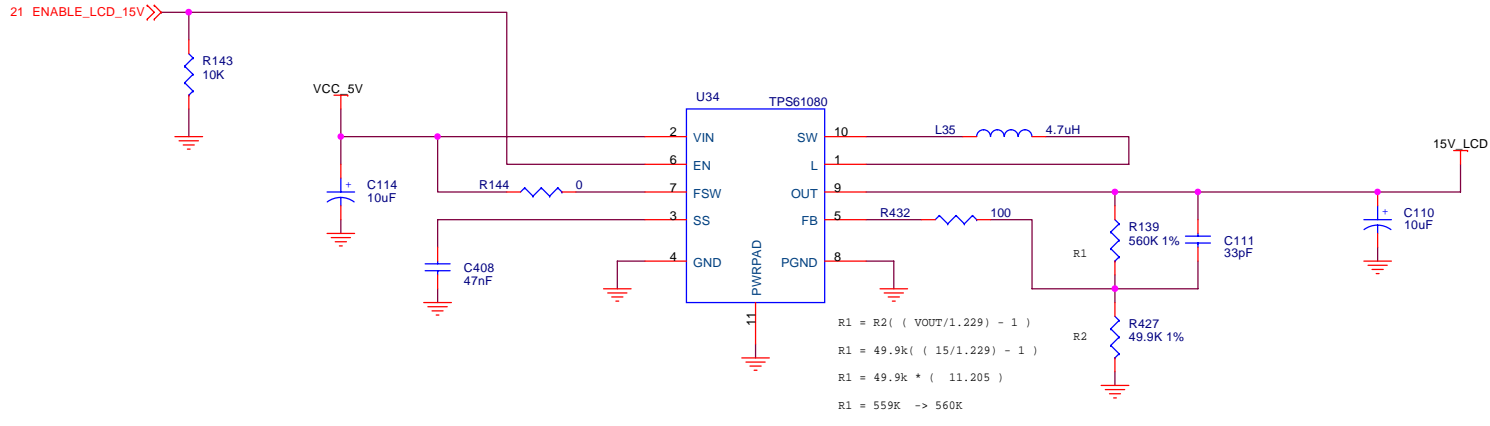

SPECTRUM DIGITAL INCORPORATED			
Title: DM365 Evaluation Module			
Page Contents: POWER SUPPLY			
Size: B	DWG NO	510842-0001	Revision: C
Date:	Monday, April 13, 2009	Sheet 49 of	53

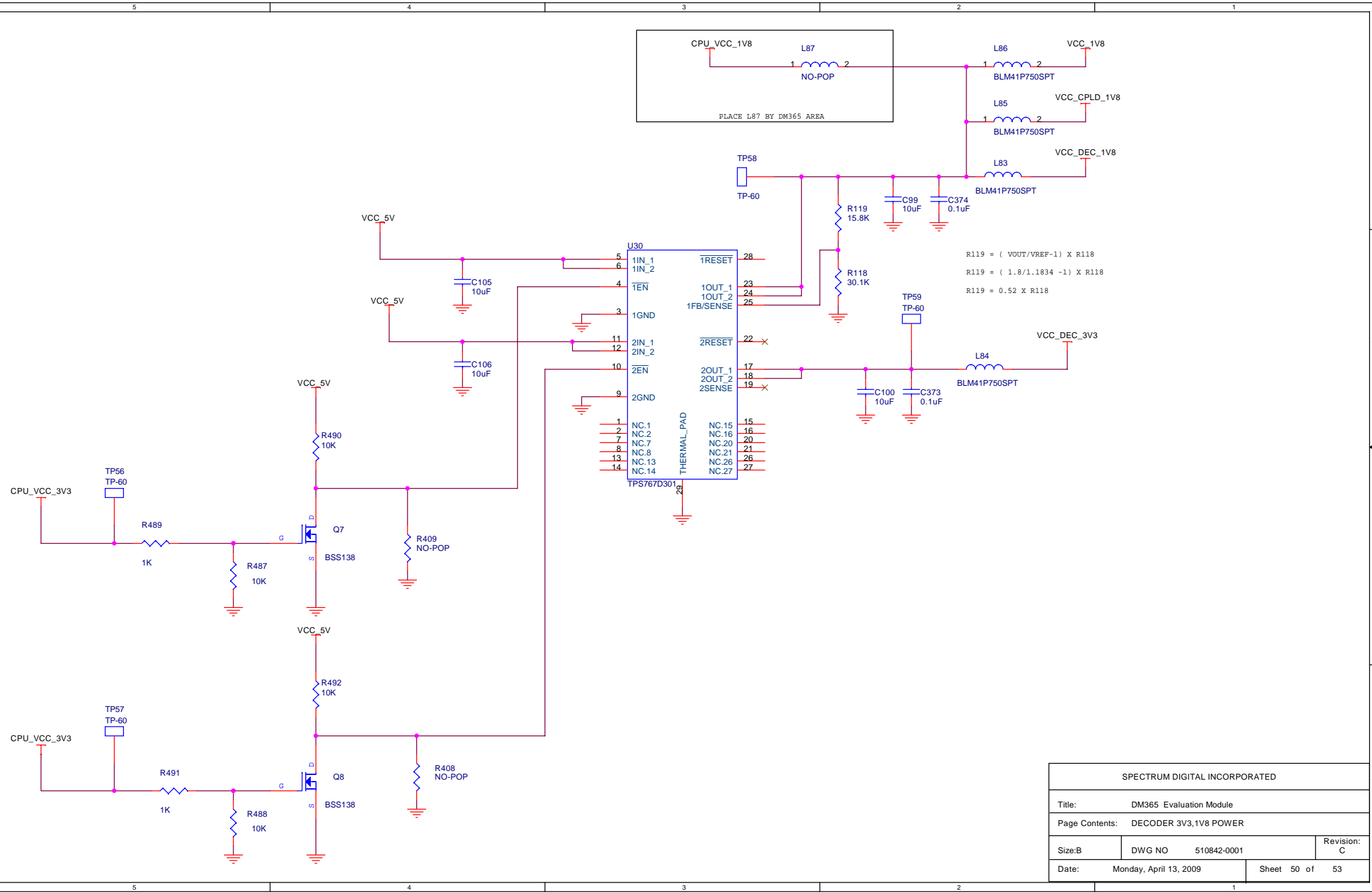

SPECTRUM DIGITAL INCORPORATED			
Title:		DM365 Evaluation Module	
Page Contents: DECODER 3V3,1V8 POWER			
Size: B	DWG NO	510842-0001	Revision: C
Date:	Monday, April 13, 2009	Sheet	50 of 53

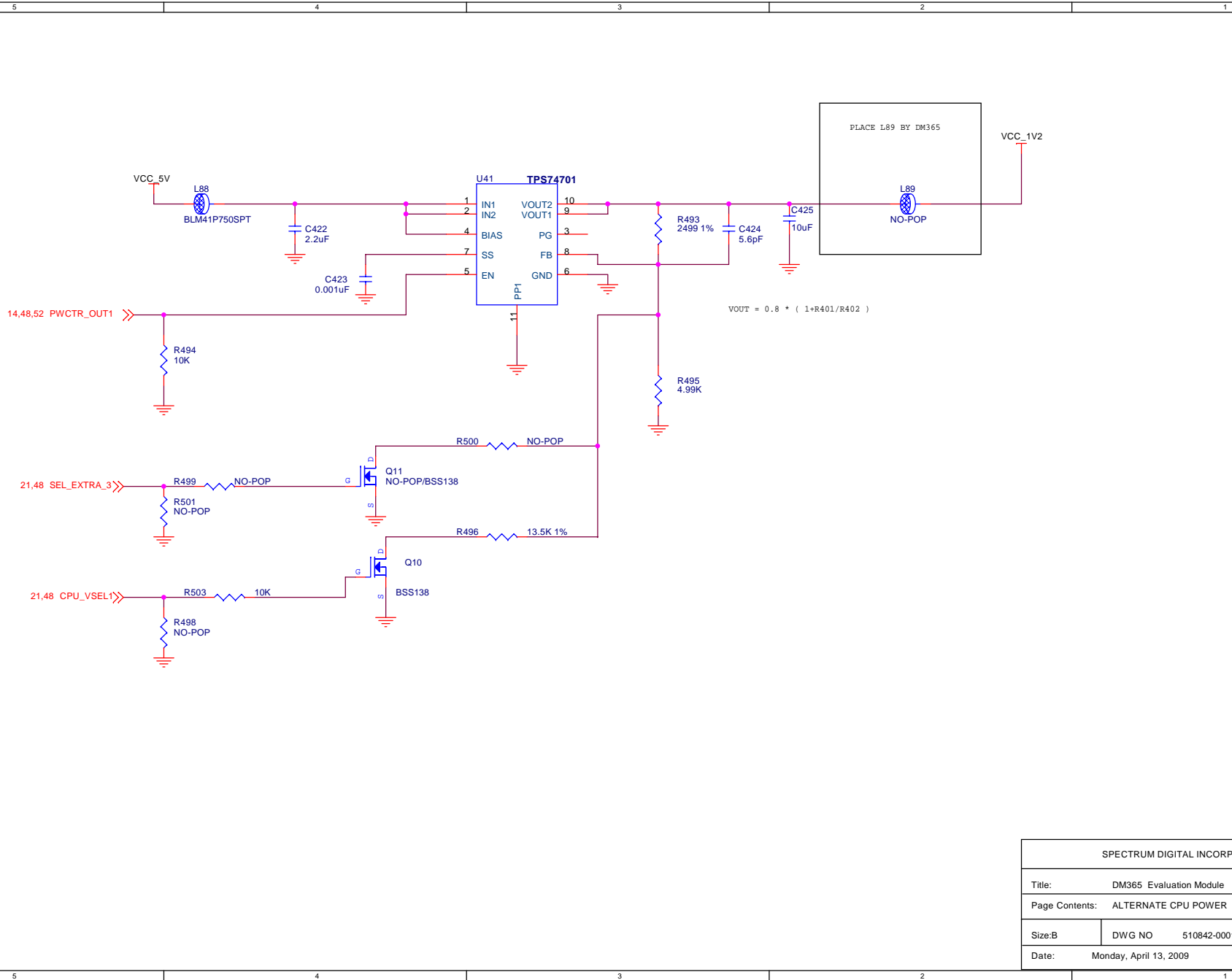

SPECTRUM DIGITAL INCORPORATED			
Title:		DM365 Evaluation Module	
Page Contents: ALTERNATE CPU POWER			
Size: B	DWG NO	510842-0001	Revision: C
Date:	Monday, April 13, 2009		Sheet 51 of 53

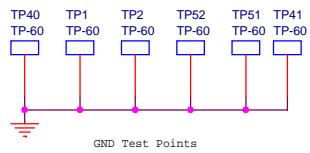
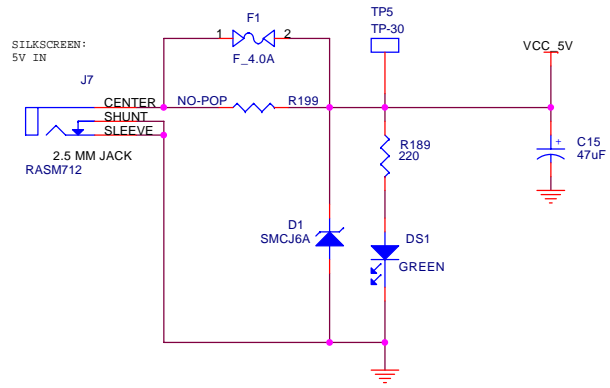

SPECTRUM DIGITAL INCORPORATED			
Title:		DM365 Evaluation Module	
Page Contents: POWER INPUT			
Size:B	DWG NO	510842-0001	Revision: C
Date:		Monday, April 13, 2009	Sheet 53 of 53